



International Union of Operating Engineers Local 150
Apprenticeship & Skill Improvement Program

2025-2026 Training Schedule and Course Catalog



James M. Sweeney,
Chairman
Local 150 Apprenticeship & Skill
Improvement Program

David Snelten,
Secretary-Treasurer
Local 150 Apprenticeship & Skill
Improvement Program

19800 W. South Arsenal Road Wilmington, Illinois 60481 (815) 722-3201



International Union of Operating Engineers, Local 150 Apprenticeship and Skill Improvement Program

James M. Sweeney, Chairman

Address 19800 West South Arsenal Road, Wilmington, Illinois 60481
Phone (815) 722-3201 • Fax (815) 423-5749 • Web www.asiplocal150.org

Introduction

Brothers and Sisters,

Our industry never stands still - and neither should we. Every year brings new equipment, new technology, and new safety practices. To keep providing for our families and protecting each other on the job, we must keep our skills sharp and stay ahead of the curve.

This catalog is your roadmap to growth. Every course you take, every skill you sharpen, makes you stronger, more versatile, and more valuable on any jobsite. It's not just training - it's an investment in your career, your safety, and your future.

Our reputation as the most skilled operating engineers anywhere is earned every day. It's up to us to uphold that standard. Take pride in your craft. Use the offseason to head to the Training Center, learn something new, or brush up on skills you haven't practiced in a while.

Commit to yourself and your trade. Every hour you invest pays dividends in safety, opportunity, and pride. Step up, stay sharp, and let's keep building the future together.

United We Stand, Divided We Fall.



James M. Sweeney
President - Business Manager
IUOE Local 150,
Chairman
IUOE Local 150 Apprenticeship
& Skill Improvement Program

COVID - 19

Policies and Procedures

Due to the COVID-19 (coronavirus) pandemic, the Local 150 ASIP Training Center is taking proactive steps to address several concerns regarding training and instruction. First and foremost, we want to maintain a safe workplace for our employees and a safe training atmosphere for our members.

The Local 150 ASIP Training Center will follow the recommendations of the Centers for Disease Control and Prevention (CDC) and the Illinois Department of Public Health (IDPH) while conducting business. Starting now, and during the upcoming training season, we will do our best to update all employees, members and visitors of current prevention strategies and policies in place and we respectfully request that everyone adhere to the current policy in place before entering the building to begin training. Your cooperation is greatly appreciated.



**U.S. Department of
Health and Human Services**
Centers for Disease
Control and Prevention



For COVID Resources, Please Visit:

<https://www.cdc.gov/>

or

<https://www.dph.illinois.gov/>

Table of Contents

Course Registration Information	4	Introduction to Demolition	17
Policy and Usage Information	4-6	Introduction to Excavators	18
Member Education	7-8	Mass Dirt	18
Labor Education	7	Introduction to Combination Backhoe	19
Know Your Union	7	Introduction to Gradalls	19
COMET	8	Introduction to Hydro-Vac Excavation	19
Labor Studies	8	Dirt Equipment Certification	20
First Aid	8	Advanced Excavator Techniques	20
Standard First Aid/CPR/AED	8	Advanced Dozer Techniques	20
Safety Instruction	9-12	Advanced Blade Techniques	20
OSHA 10-Hour & 30-Hour Safety Awareness	9	Road Construction	21-23
40-Hour Hazmat & 8-Hour Refreshers	10	Introduction to Asphalt Paving and Rolling	21
OSHA Disaster Site Worker	10	Fundamentals of Asphalt Paving and Rolling	22
Confined Space Awareness	11	Introduction to Road Grinding	22
Mobile Elevated Work Platform	11	Intro to Material Transfer Vehicles and Road Wideners	22
OSHA Powered Industrial Truck	11	Concrete Pumping	22
Vermeer PD-10 Pile Driver	12	Introduction to Concrete Plants	23
Mine Safety	12-13	Assistant Plant Operator	23
MSHA Surface New Miner	12	Sitework, Staking, GPS and Drones	24-26
MSHA Surface Refresher	13	Grade Stakes, Layout and Plan Reading	24
MSHA Underground New Miner	13	Introduction to Digital Take-Off	24
MSHA Underground Refresher	13	GPS: Survey and Rover Pole	25
Pipeline Industry	14-15	GPS and Machine Control	25
Introduction to Pipeline and Gas Distribution	14	Drone - Levels 1 & 2	26
Pipeline Sideboom Techniques	14	Operating Engineers Certification Program	27
Pipeline Excavator Techniques	15	OECP Test Dates	27
Mass Dirt, Demolition and Hydro-Vac	15-20	Crane Department	28-32
Introduction to Sewer and Water Principles	15	Introduction to Cranes	29
Basement Digging	16	Fundamentals of Hoisting and Rigging	29
Introduction to Skid-Steer Loaders	16	Introduction to Tower Cranes	29
Introduction to Dozers	16	Advanced Hoisting and Rigging	30

Table of Contents (cont.)

Principles of Friction Cranes	30	Caisson Drill Rig Class	42
Signal Person Safety Training	31	Construction Material Inspectors	43-54
Rigging Person Safety Training	31	ICC General Requirements Special Inspector	43
Mobile Crane	31	Math I & II	44
Crane Math and Load Charts	32	Concrete Inspection Classes	44-46
Liebherr 1095 Assembly/Disassembly	32	Masonry Inspection Classes	47
Heavy Equipment Technician Classes	33-38	Soils Inspection Classes	48-49
4-Section Telescopic Boom D & A	33	Structural Steel Inspection Classes	49-50
Engine Disassembly and Assembly	33	Introduction and IDOT Classes	52-54
Power Train Systems	33	American Concrete Institute (ACI)	54
Journey Worker Hydrostatic Systems	33	ACI Concrete Field Testing Inspection Grade 1	54
Tier 4 Diesel Engine Emission Systems	34	Commercial Truck Driving	55
Journey Worker Hydraulics	35		
Journey Worker Electrical	35		
Computer Based Diagnostics	36		
Electronic Systems	36		
Introduction to Electric Drive Systems	37		
Metal Fabrication and Basic Repair	37		
Mechanical Diesel Fuel Systems	38		
Intro to Mobile A/C-MACS 609 Cert. (AC1)	38		
Theory of Mobile A/C Testing & Adjusting (AC2)	39		
Heavy Equipment Welding Classes	40		
FCAW and GMAW Welding	40		
SMAW (Stick Welding) / NC3 Certification	40		
Shielded Metal Arc Welding	40		
Drilling Classes	41		
Exploratory Drilling Levels 1 & 2	41		
Introduction to Geothermal Drilling	41		
HDPE Pipe Fusion	41		
Introduction to Geothermal Systems	42		

Course Registration Information

Registration for this fall season will be limited to classes occurring within a 30-day period from the date that you call in to register. So for example; if you call in to register for a class on October 1st, you will only be able to register for classes starting in October through November 1st. This should alleviate a couple of issues at the site, one being the flood of calls that normally take place the first few weeks of registration and second being a reduction in the amount of no-shows that occur later in the season as members start to return to work or forget they signed up for a class three months prior.

ASIP is now offering online registration for a limited number of classes. Classes with prerequisites will not be available for online registration at this time. Please visit www.asiplocal150.org to view our upcoming classes. Once you login, you can click on the “Member Services” link listed in the center of the main page where you will then find the “Classes” link. The classes available for online registration will have a “Register” link next to the number of open spaces in the class. Once signed up, you will receive an email confirmation as long as you have a valid email on file with the Apprenticeship Office. If you do not have an email address on file with the Apprenticeship Office, you will still be registered. If you are not able to attend class once registered, we please ask that you re-visit the site to cancel your registration or call us at 815-722-3201

Training Center Policy and Usage Information

Dress Code

All members using the Training Center must wear shirts with sleeves (long or short), no tank tops or sleeveless shirts, full length pants (no shorts) and work boots (no tennis shoes or dress shoes).

Personal Protective Equipment

All members training outside of the classroom are required to bring their own hard hat, safety vest, and hearing protection.

Equipment Sign Out Shifts

Machines are available for sign out two sessions or shifts per day, morning (7 a.m. – 11 a.m.) or the afternoon (11:30 a.m. – 3:30 p.m.).

All equipment must be signed in and out before and after each shift in the equipment sign out room located in the corner of the cafeteria.

Equipment Reservations

Members may reserve equipment up to 30 days in advance.

You may reserve a machine for up to four shifts per week (16 total hours per week), once the four shifts have been met, you must reserve a different machine for the remainder of that week.

Reservations are held until 7:05 a.m. for the morning shift and 11:35 a.m. for the afternoon shift, these machines will be released for sign out after these times.

If you have a machine reserved and are running late, please call the Training Center at (815)-722-3201 and we will hold your reservation for up to 30 minutes.

If you have a reservation and will not be able to make it to the site that day, we ask you to call the Training Center and cancel your reservation, so another member can make use of that machine. Failure to cancel by phone will result in restrictions on future machine reservations.

Equipment Usage

Pre-operation

- Check all fluids and top them off if necessary. If you have any questions about proper fluids or levels, please ask an instructor.
- Grease all grease fittings, being sure not to over-grease.

Operation:

- Please be careful climbing in and out of ditches.
- Be sure to back fill and level off your work area prior to exiting the field or arena at the end of your shift.
- Be sure to fuel the machine after operation unless otherwise told.
- If operating a tracked machine, please clean the tracks at the end of your shift.
- Please clean all garbage from the cab at the end of your shift.

Classroom Policies

Please utilize the same dress code as stated earlier; you may be required to leave the classroom for the field for hands-on training or demonstrations.

Attendance will be taken; you will need to sign the attendance sheet next to your name.

Snacks, coffee, soda and water may be brought into the classroom, please refrain from bringing breakfast and lunch into the classroom (use the cafeteria). Please clean up after yourself if you bring these items into the classroom.

Classroom Walk-In Policies

In order to maintain the best possible classroom and hands-on experience, class size has been limited. Once a scheduled class has been filled during registration, a waiting list will be created for that class. Those who wish may be put on this list. This waiting list will be used to fill slots opened by cancellations and no-shows. On the first day of class, attendance will be taken. If there are any openings for the class, they will first be filled with those present and on a waiting list, then by those waiting and not on a list.

Members on the waiting list will be listed in order by their sign up date and time.

Hotel Usage Policies

All members who live 30 miles or more from the Training Center and are using the site for two full consecutive days (16 hours) or more are eligible to utilize a hotel arranged by us at our expense for the nights in between training days.

Upon checking into the hotel, you will be asked for a credit card. This is required by the hotel to be used for the coverage of incidental charges (telephone, damage, etc.). You will not be allowed to check in without one.

If you utilize a hotel and do not fulfill the two consecutive days (16 hours) of training, the full hotel bill will be billed to you.

Supervised Training

The purpose of this training is to give the applicant the ability to gain hands-on experience through training with the supervisor.

It is the responsibility of the supervisor to stay with the applicant during the pre-operation checks, and advise on safety and operating techniques of the machine. This training is limited to skid steers, rubber tired loaders, small dozers and combination backhoes.

Equipment sign out is on a first come, first serve basis once all Journeyworkers and Apprentices have signed out. If you will be training out in the dirt field, you will need to see an instructor who will assign you a vehicle and a place in the field to train.

Cafeteria

The cafeteria is open during regular business hours.

Speed Limit

As a reminder, the speed limit on South Arsenal Road is 45 mph. Please adhere to this as it is enforced on a daily basis.

IUOE International Training Site Travel Policies

Class/Travel Registration

All class registration and travel will require prior approval of the ASIP POC and/or JATC Chairman.

Request must be submitted to the International's Travel coordinator through the ITRS website. (iuoe-itrs.org) All travel reservations will be booked through the I.U.O.E travel coordinator.

All flights will be booked at the most economical price for the fund and at the discretion of the I.U.O.E Travel Coordinator.

Rental Cars, Personal Vehicles & Airport Shuttle

Rental Cars are not authorized for any travel for training at the I.T.C.C.

Personal vehicle use for travel is not authorized to the I.T.C.C.

Parking and Taxi (UBER/LYFT/RIDE SHARING) are not authorized and will not be reimbursed.

Travel to and from home airport is not reimbursed.

Shuttle service is provided at I.T.C.C.

Flights, Baggage & Meals

Flight/seat (early bird check-in) upgrades will not be reimbursed.

Baggage fees will be reimbursed only on flights that do not include baggage in the air fare with original receipt for payment there will be no exceptions. Extra bag and overweight baggage fees will not be reimbursed.

Flights to attend training at I.T.C.C. are provided by the NTF (National Training Fund). Misappropriation of these funds are grounds for charges being filed against members of the I.U.O.E. Any member misappropriating funds will be directed to meet with the advisory board of their home district for the possibility of charges being leveled against them. (constitution Article XVI sec 3 and XXIV subsection 7 sec (e); local bylaws Article IX sect 6 (a)(c).

Meal expenses will not be reimbursed, all meals are provided by I.T.C.C.



Member Education

Labor Education*

This program of study critically assesses the fundamental historical events, decisions, and developments which have shaped America's modern working class. The course contends that labor history is the conjunction of two dynamic struggles: the courageous efforts of individual working men and women to win dignity and security from

their employers, and the broader struggle of all working people to provide food, shelter, education, personal fulfillment and a sense of community for themselves and their families. The history of organized labor is about emancipating all people from oppression. Members will learn about the causes of these struggles, what forces were aligned against the working class, what techniques workers used to fight for justice and why these battles are important to understanding the role of organized labor in American society. *Note:* This class is not a replacement for the "Labor Studies & COMET 1" class put on in Countryside.

* All apprentices must take Labor Ed 1, 2 & 3 to satisfy their apprenticeship requirements.

Level	Date	Start Time	Location
1	Oct. 11, 2025	11:00 A.M. - 2:00 P.M.	Auditorium
2	Oct. 18, 2025	8:00 A.M. - 11:00 A.M.	Auditorium
3	Oct. 18, 2025	11:30 P.M. - 2:30 P.M.	Auditorium
1	Jan. 10, 2026	11:00 A.M. - 2:00 P.M.	Auditorium
2	Jan. 25, 2026	8:00 A.M. - 11:00 A.M.	Auditorium
3	Jan.25, 2026	11:30 A.M. - 2:30 P.M.	Auditorium
1	Mar. 7, 2026	11:00 A.M. - 2:00 P.M.	Auditorium
2	Mar. 21, 2026	8:00 A.M. - 11:00 A.M.	Auditorium
3	Mar. 21, 2026	11:30 A.M. - 2:30 P.M.	Auditorium

Know Your Union

Know Your Union is a four-hour course designed to familiarize new and existing members with various aspects of Local 150, including organizational history, governance, hiring hall, training, benefits, and political activism. *Note:* Additional classes will be scheduled throughout the year. Please visit: www.local150.org or www.asiplocal150.org for more information and class dates. Contact the District 1 Hall at (708) 482-8800 to reserve your spot in these classes.

Date	Start Time	Location
Nov. 15, 2025	8:00 A.M.-Noon	District 1 Hall
Jan. 24, 2026	8:00 A.M.-Noon	District 1 Hall
May 2, 2026	8:00 A.M.-Noon	District 1 Hall
Aug. 29, 2026	8:00 A.M.-Noon	District 1 Hall
Nov. 21, 2026	8:00 A.M.-Noon	District 1 Hall

Labor Studies & COMET 1 *

COMET stands for Construction Organizing Membership Education Training, and helps members understand why organizing is central to maintaining bargaining strength. It generates membership support and encourages rank and file participation in the Local's organizing efforts.

Labor Studies is a thorough review of the history of the American Labor Movement, including its successes and failures in the

past and the challenges that lie in the future. **Note:** Additional classes will be scheduled throughout the year. Please visit: www.local150.org or www.asiplocal150.org for more information and class dates. To reserve your place at these classes, contact the District 1 Hall at (708) 482-8800.

Date	Start Time	Location
Oct. 11, 2025	8:00 A.M.-11:00 A.M.	ASIP (COMET Only)
Nov. 22, 2025	8:00 A.M.-12:00 P.M.	District 1 Hall
Jan. 10, 2026	8:00 A.M.-11:00 A.M.	ASIP (COMET Only)
Feb. 7, 2026	8:00 A.M.-12:00 A.M.	District 1 Hall
Mar. 7, 2026	8:00 A.M.-11:00 P.M.	ASIP (COMET Only)
May 9, 2026	8:00 A.M.-11:00 P.M.	District 1 Hall
Sep. 12, 2026	8:00 A.M.-12:00 P.M.	District 1 Hall
Dec. 19, 2026	8:00 A.M.-12:00 P.M.	District 1 Hall

* The Labor Studies portion of this class does not have to be taken by apprentices to satisfy their apprenticeship requirements.

First Aid



**American
Red Cross**

Standard First Aid, CPR, AED

In this 8-hour class you will learn how to respond to common first aid emergencies including: burns, cuts, head, neck injuries, back injuries and more. In the CPR and AED portion, you will learn how to respond to cardiac and breathing emergencies in adults, including the use of an automated external defibrillator (AED). There is an emphasis on hands-on learning in this course and after successfully completing it, members will receive a certification card that is valid for two years.

Date	Start Time	Location
Nov. 24, 2025	7:00 A.M.	2129
Dec. 15, 2025	7:00 A.M.	2129
Jan. 26, 2026	7:00 A.M.	2129
Jan. 29, 2026	7:00 A.M.	2129
Feb. 4, 2026	7:00 A.M.	District 8
Feb. 23, 2026	7:00 A.M.	2129

Safety Instruction

OSHA 10-Hour Safety Awareness

This course will help members recognize and control a variety of safety and health hazards frequently found in today's workplace. Contractors are recognizing the value of this training and some job sites may require this for entry. This class is a prerequisite to the OSHA 30 and Disaster Site Worker classes. Please check the start time for the class that you're interested in taking. The classes will run 7:00a.m. - 3:30p.m. for two consecutive days. **Note: 40 member max per class.**

Date	Start Time	Location
Nov. 11-12, 2025	7:00 A.M.	2110
Nov. 18-19, 2025	7:00 A.M.	2110
Dec. 2-3, 2025	7:00 A.M.	2110
Jan. 6-7, 2026	7:00 A.M.	2110
Jan. 13-14, 2026	7:00 A.M.	2110
Feb. 2-3, 2026	7:00 A.M.	District 8
Feb. 3-4, 2026	7:00 A.M.	2110
Feb. 10-11, 2026	7:00 A.M.	2110
Feb. 17-18, 2026	7:00 A.M.	2110
Mar. 3-4 2026	7:00 A.M.	2110
Mar. 10-11, 2026	7:00A.M.	2110
Mar. 17-18, 2026	7:00A.M	2110

OSHA 30-Hour Safety Awareness

The OSHA 30-Hour course is a five day course with the intent of assisting employers in training and introducing operators to the basic practices of identifying, reducing, eliminating, and reporting hazards associated with their work. There will be formal classroom instruction, quizzes, short presentations as well as hands-on exercises addressing hazard recognition. Satisfactory completion of the course requires full attendance and a passing score on the final exam. Participants are required to have a valid OSHA 10-Hour Construction card to enroll in class and must present card to instructor on first day of class.

Date	Start Time	Location
Jan. 26-30, 2026	7:00 A.M.	1051
Apr. 6-10, 2026	7:00 A.M.	1051

40-Hour Hazardous Material Awareness

This course prepares operators to work safely and effectively with hazardous materials on and off hazardous waste sites. The 40-hour Hazardous Materials Awareness and Certification Course is required of everyone working on a Haz-Mat job. Attendance is required for all 40 hours of training. Members must be clean-shaven to participate in respirator training. Members who successfully complete this course must receive 8-hours of refresher training annually. Note: 18 member max per class.

Date	Start Time	Location
Nov. 3-7, 2025	7:00 A.M.	1051
Dec. 8-12, 2025	7:00 A.M.	1051
Jan. 19-23, 2026	7:00 A.M.	1051
Feb. 23-27, 2026	7:00 A.M.	1051
Mar. 23-27, 2026	7:00 A.M.	1051
Mar. 30-Apr. 3, 2026	7:00 A.M.	1051

8-Hour Hazardous Material Refresher

OSHA regulations require that graduates of the 40-hour Haz-Mat classes attend an annual 8-hour Haz-Mat refresher. Haz-Mat refresher training is scheduled on Saturdays and is held at the Training Center and at several of the District Halls. Local 150 Haz-Mat graduates are notified by mail of their scheduled refresher class a few weeks before their certificate expiration date. Haz-Mat refresher classes review the key components of the Haz-Mat 40-hour training, provide the opportunity to discuss various aspects of the Haz-Mat work in our jurisdiction, and examine new and developing technologies in the Haz-Mat workplace.

Date	Start Time	Location
Nov. 1, 2025	7:00 A.M.	Auditorium
Dec. 6, 2025	7:00 A.M.	District 5
Jan. 10, 2026	7:00 A.M.	District 4
Jan. 17, 2026	7:00 A.M.	District 1
Feb. 7, 2026	7:00 A.M.	District 3
Feb. 21, 2026	7:00 A.M.	District 8
Feb. 21, 2026	7:00 A.M.	District 6
Mar. 7, 2026	7:00 A.M.	District 7
Mar. 28, 2026	7:00 A.M.	Auditorium

OSHA Disaster Site Worker

This course is intended for Disaster Site Workers who provide skilled support services (e.g., utility, demolition, debris removal, or heavy equipment operation) or site clean-up services in response to a disaster. During this 2 day course, we will satisfy the FEMA requirements for ICS-100, ICS-200 and NIMS-700 courses as well as OSHA #7600 Disaster Site Worker. Because this course does not cover in detail safety and health hazards that occur on a daily basis on a normal construction site, completion of the OSHA Construction Outreach Training Course (10-hour) is a prerequisite.

Date	Start Time	Location
Dec. 16-17, 2025	7:00 A.M.	1051
Apr. 14-15, 2026	7:00 A.M.	1051

Confined Space Awareness

This 2-day course involves both classroom instruction and hands on training. During the classroom portion, instructors will cover topics associated with both non-permit and permit required confined spaces. Members will also receive instruction on OSHA standards such as Control of Hazardous Energy, Air Monitoring and Fall Protection. During hands on training, members will safely enter multiple confined spaces using proper procedures to carry out the necessary work to be performed. Class size will be limited to 15 members. There are no prerequisites required to take this class.

Date	Start Time	Location
TBD	7:00 A.M.	1051

Mobile Elevated Work Platform

During this 2-day course, members will learn OSHA and ANSI standards related to the safe operation of Mobile Elevated Work Platforms (MEWP). Some examples of a MEWP are truck mounted boom lifts, scissor lifts and bucket trucks. Upon successful completion of the classroom portion, members will be tested on 3 different classes of MEWP's. After fulfilling all requirements, members will receive an accredited Powered Access License (PAL) card from the International Powered Access Federation that is valid for 5 years. Class size will be limited to 12 members. There are no pre-requisites required to take this class. **Note:** Members looking to renew their PAL license should call and make an appointment at the training site before their license expires.

Date	Start Time	Location
Nov. 24-25, 2025	7:00 A.M.	1051
Feb. 2-3, 2026	7:00 A.M.	1051
Mar. 16-17, 2026	7:00 A.M.	1051

OSHA Powered Industrial Truck (PIT)

OSHA regulations require that all powered industrial truck operators are trained, evaluated and certified before they operate a forklift. This two-part course covers training requirements. The first part involves classroom instruction in the form of lecture, discussion, videos and a multiple choice test. Members must achieve a passing score of 80 percent or higher. The second part of the training requirement is applied during a practical exercise which involves testing on an electric forklift, two LPG industrial forklifts and a rough terrain forklift. This training allows the members to obtain four out of the seven classes of industrial powered trucks on their training card. The member will be evaluated and certified by the employer in accordance with the OSHA standard.

Date	Start Time	Location
Nov. 17, 2025	7:00 A.M.	2111
Dec.1, 2025	7:00 A.M.	2111
Dec. 29, 2025	7:00 A.M.	2111
Feb. 2, 2026	7:00 A.M.	2111
Mar. 2, 2026	7:00 A.M.	2111

Vermeer PD-10 Pile Driver

This three-day class is designed to develop the skills necessary to safely and efficiently operate the PD-10 Pile Driver which has become very common in the Solar Industry. Our PD-10 is outfitted with Leica's GPS Navigation equipment for precise installation of pilings. Students will learn safe pre-inspection and start-up procedures as well as machine operation and GPS and Laser operating procedures. Please dress according to weather as much of this training will be outside. **Note: 6 members max per class.**

Date	Start Time	Location
Dec. 15-17, 2025	7:00 A.M.	1051
Jan 26-28, 2026	7:00 A.M.	1051
Feb. 16-18, 2026	7:00 A.M.	1051

Mine Safety

MSHA Surface New Miner

The MSHA Training Plan Part 48, Subpart B that Local 150 ASIP has filed with MSHA covers surface metal non-metal mining and is accepted by MSHA to cover Part 46 training since Part 48, Subpart B training is a higher standard than Part 46. A requirement of the mine training plan is that any new employee designated as a non-experienced miner must receive 24 hours of new miner training to work at a mine site. Training must include instruction in safety and health subjects that are relevant to mining operations. The company you go to work for must supply you with all site specific and task training under Part 46 or Part 48, Subpart B before you start work. All experienced miners must receive 8 hours of refresher training each year to continue working at a mine site. **Note: 18 member max per class.**

Date	Start Time	Location
Dec. 1-4, 2025	7:00 A.M.	2129
Jan. 26-29, 2026	7:00 A.M.	2129
Feb. 2-5, 2026	7:00 A.M.	2129
Feb. 9-12, 2026	7:00 A.M.	2129
Mar. 9-12, 2026	7:00 A.M.	2129
Mar.30-Apr.2,2026	7:00 A.M.	2129



MSHA Surface Refresher

The MSHA Training Plan, Subpart B Local 150 ASIP has filed with MSHA covers surface metal non-metal mining and is accepted by MSHA to cover part 46 training since Part 48, Subpart B training is a higher standard than Part 46. A requirement of the mine training plan is that any employee designated as an experienced miner must receive 8 hours of refresher training each year to work at a mine site. Refresher training must include instruction on the following: safety and health subjects that are relevant to mining operations. You must have proof of prior MSHA training to attend this class. A 24-hour New Miner certificate, or a refresher certificate will be accepted as proof that you are a experienced miner. The company that you go to work for must supply you with all site specific and task training under Part 46 or Part 48, Subpart B before you start work.

Date	Start Time	Location
Dec. 6, 2025	7:00 A.M.	2129
Jan. 9, 2026	7:00 A.M.	District 5
Jan. 10, 2026	7:00 A.M.	District 5
Feb. 13, 2026	7:00 A.M.	District 4
Feb. 14, 2026	7:00 A.M.	District 4
Mar. 7, 2026	7:00 A.M.	2129
Mar. 21, 2026	7:00 A.M.	District 7
Apr. 4, 2026	7:00 A.M.	2129

MSHA Underground New Miner

The MSHA Part 48 A Underground training plan Local 150 ASIP has filed with MSHA covers underground metal and non-metal mining and has been accepted by MSHA to train underground new miners. A requirement of the mine training plan is that any new employee designated as a non-experienced miner must receive 40 hours of underground new miner training to work at an underground mine site, 8 hours of which must be at an underground mine. The final 8 hours of this class will be underground at a local underground limestone mine. After taking this class and having 12 months experience, you will be considered an experienced underground miner by MSHA. The company that you go to work for must supply you with all site specific and task training before you start work. All experienced underground miners must receive 8 hours of underground refresher training each year to continue working at an underground mine site. *Prerequisites:* MSHA Surface New Miner or an up to date MSHA Surface Refresher. **Note: 15 member max per class.**

Date	Start Time	Location
Jan. 12-16, 2026	7:00 A.M.	2129
Feb. 16-20, 2026	7:00 A.M.	2129
Mar. 23-27, 2026	7:00 A.M.	2129

MSHA Underground Refresher

The MSHA Part 48 A Underground training plan that Local 150 ASIP has filed with MSHA covers underground metal and non-metal mining and has been accepted by MSHA to train underground new miners. A requirement of the mine training plan is that any employee designated as an experienced underground miner must receive 8 hours of underground refresher training each year to work at an underground mine site. Refresher training must include instruction on the safety and health subjects that are relevant to mining operations. You must have proof of prior MSHA training to attend this class. A 40-hour underground new miner certificate or an underground refresher certificate will be accepted as proof you are an experienced miner. The company you go to work for must supply you with all site specific and task training before you start work.

Date	Start Time	Location
Jan. 17, 2026	7:00 A.M.	2129
Feb. 21, 2026	7:00 A.M.	2129

Pipeline Industry



Introduction to Pipeline and Gas Distribution Systems

This 40-hour class is intended to allow members to develop the skills necessary for employment in the pipeline and gas distribution industries. This course will be taught by experienced pipeline operators and will include hands on field exercises which will allow our members to become more employable in these industries. **Note: 15 member max per class.**

Date	Start Time	Location
Nov. 10-14, 2025	7:00 A.M.	2121
Dec. 15-19, 2025	7:00 A.M.	2121
Jan. 26-30, 2026	7:00 A.M.	2121
Apr. 6 -10, 2026	7:00 A.M.	2121

Pipeline Sideboom Techniques

This 40-hour Pipeline sideboom class offers our members the opportunity to develop the skills necessary for sideboom work on a pipeline spread. Hands-on instruction by experienced pipeliners will concentrate on the development of skills such

as catching your drift, carrying joints of pipe, carrying sections, carrying concrete coated pipe, general machine control, etc. *Prerequisites:* 500 or more pipeline work hours or previously taken Pipeline, Introduction to Gas Distribution or Introduction to Pipeline and Gas Distribution Systems courses.

Note: 4 member max per class.

Date	Start Time	Location
Feb. 2-6, 2026	7:00 A.M.	2121
Mar. 2-6, 2026	7:00 A.M.	2121

Pipeline Excavator Techniques

This 40-hour Pipeline Excavator class offers our members the opportunity to develop the skills necessary for excavator work on a pipeline spread. Hands-on instruction by experienced pipeliners will concentrate on the development of skills such as digging ditch, bell holes, excavating near live lines, digging road approaches, handling of mats, etc. *Prerequisites:* 500 or more pipeline work hours or previously taken one of the following classes: Pipeline, Introduction to Gas Distribution or Introduction to Pipeline and Gas Distribution Systems. **Note: 6 member max per class.**

Date	Start Time	Location
Nov. 17-21, 2025	7:00 A.M.	2121
Feb. 2-6, 2026	7:00 A.M.	2121
Mar. 2-6, 2026	7:00 A.M.	2121

Mass Dirt, General Underground, Excavation & Demolition

Introduction to Sewer and Water Principles

This class was designed for the operator with experience on an excavator or track loader, who is interested in how these machines are utilized in the Sewer and Water industry. Topics to be covered in this class are: working with trench boxes, stone misers, laying sewer pipe, safety habits and materials common to the sewer and water industry, as well as some basic blueprint and plan reading. This class will be a blend of classroom lessons and discussion, all of which will be backed up with hands-on exercises in the field. *Prerequisites:* Excavator or Loader proficiency or completion of the Introduction to Excavator class. Members attending this class must attend all classroom activities in order to move on to the hands-on portion of the class. Members should be proficient on an Excavator or Combination Backhoe before attending this course.

Note: 8 member max per class.

Date	Start Time	Location
Dec. 1-5, 2025	7:00 A.M.	1133
Jan. 5-9, 2026	7:00 A.M.	1133
Jan. 26-30, 2026	7:00 A.M.	1133
Mar. 16-20, 2026	7:00 A.M.	1133
Mar.30-Apr.3, 2026	7:00 A.M.	1133

Basement Digging

This 40-hour class is intended for the experienced excavator or track loader operator interested in learning how to dig residential basements. This class will cover blueprint reading, setup and use of a laser, layout, placement of spoils, and excavation. You can expect a blend of classroom and hands-on training. Members must be proficient on an excavator to attend this class. **Note: 8 member max per class.**

Date	Start Time	Location
Nov. 17-21, 2025	7:00 A.M.	1140
Mar. 23-27, 2026	7:00 A.M.	1140

Introduction to Skid-Steer Loaders

This 40-hour class will focus on the basic fundamentals of a skidloader. In this class, members will learn the different control patterns, use a variety of different attachments, load trucks and also cut grade for a sidewalk and/or driveway. Also, members will practice loading and unloading their machines and attachments onto and off of a trailer. Through approximately 8 hours of lecture in the classroom and 32 hours hands-on learning in the seat of a machine, this class will try to duplicate multiple real world scenarios. No testing will be done during this class. **Note: 8 member max per class.**

Date	Start Time	Location
Nov. 17-21, 2025	7:00 A.M.	1140
Jan. 12-16, 2026	7:00 A.M.	1140
Jan. 26-30, 2026	7:00 A.M.	1140
Feb. 23-27, 2026	7:00 A.M.	1140
Mar. 30-Apr. 3, 2026	7:00 A.M.	1140

Introduction to Dozers

This class is designed for the beginning dozer operator. This course teaches pre-operational checks and inspections, safety, develops familiarity with control functions, basic dozer techniques including slot dozing, v-ditches, proper traveling speeds, cuts and fills, striping and stockpiling, and backfilling of trenches. This course will also include basic grade stake reading and a small amount of slope work. **Note: 8 member max per class.**

Date	Start Time	Location
Dec. 8-12, 2025	7:00 A.M.	1142
Jan. 5-9, 2026	7:00 A.M.	1142
Jan. 19-23, 2026	7:00 A.M.	1142
Feb. 2-6, 2026	7:00 A.M.	1142
Feb. 16-20, 2026	7:00 A.M.	1142
Mar. 16-20, 2026	7:00 A.M.	1142



Intro to Demo Attachments & Material Processing

This 40-hour class is designed to provide our members with the next level of machine control and skill level. Through approximately 8 hours of lecture in the classroom and 32 hours hands-on learning in the seat of multiple machines, members will learn the fundamentals of demolition. Machines that will be used during this class may include excavators with breakers and processors, loaders with buckets and forks, a concrete crusher, a screen plant that is able to process multiple material types and sizes as well as skidloaders using multiple attachments.

Prerequisites: One of the following: Skidsteer proficiency, Excavator proficiency, Combination proficiency or completion of an Introduction to Excavators or Introduction to Combination Backhoe class. **Note: 8 member max per class.**

Date	Start Time	Location
Feb. 2-6, 2026	7:00 A.M.	1141
Feb. 9-13, 2026	7:00 A.M.	1141
Mar. 2-6, 2026	7:00 A.M.	1141

Introduction to Excavators

This 40-hour class is designed for operators with minimal excavator experience. This course will include a blend of classroom discussion and hands-on training designed to enhance your skills throughout the week. This course begins in the classroom and covers several areas of safety, including machine safety, trench safety, and utility safety. We will move into the machine and work on drills designed to gain basic control of the machine and finish with basic ditching exercises and truck loading (weather permitting). **Note: 8 member max per class.**

Date	Start Time	Location
Nov. 3-7, 2025	7:00 A.M.	1133
Dec. 8-12, 2025	7:00 A.M.	1133
Feb. 16-20, 2026	7:00 A.M.	1133
Feb. 23-27, 2026	7:00 A.M.	1133
Mar. 16-20, 2026	7:00 A.M.	1133
Mar. 30- Apr. 3, 2026	7:00 A.M.	1133

Mass Dirt

This class will cover most aspects of a mass dirt job site. During this 40-hour class members will be instructed on a wide variety of dirt equipment. Machines being used in this class include excavators, articulating dump trucks, large dozers, scrapers and compactors. Members will run most, if not all, of these machines throughout the week. Some of the job site scenarios that may be performed during the week include road building, ditch work, pond excavation and building pad construction. *Prerequisites:* One of the following: Dozer proficiency, Excavator proficiency, Introduction to Excavator class or Introduction to Dozer class. **Note: 8 member max per class.**

Date	Start Time	Location
Nov. 3-7, 2025	7:00 A.M.	1140
Dec. 8-12, 2025	7:00 A.M.	1140
Jan. 12-16, 2026	7:00 A.M.	1140
Feb. 9-13, 2026	7:00 A.M.	1140
Mar. 2-6, 2026	7:00 A.M.	1140



Introduction to Combination Backhoe

This 40-hour class is designed for operators with minimal combination backhoe experience. This course will include a blend of classroom discussion and hands-on training designed to enhance your skills throughout the week. This class will start off in the classroom covering safety in and around the machine, after which we will move into the machine and work on drills designed to gain basic control of the bucket and backhoe finishing with ditching, handling street plates, and utility digs. **Note: 8 member max per class.**

Date	Start Time	Location
Dec. 1-5, 2025	7:00 A.M.	1145
Jan. 5-9, 2026	7:00 A.M.	1145
Jan. 12-16, 2026	7:00 A.M.	1145
Feb. 2-6, 2026	7:00 A.M.	1145
Feb. 23-27, 2026	7:00 A.M.	1145
Mar. 9-13, 2026	7:00 A.M.	1145

Introduction to Gradalls

This 40-hour class is designed for operators with no Gradall experience. This course will include minimal classroom with the majority of time being hands-on. The course will cover pre-operational checks and inspections, safety, daily maintenance, familiarity with control functions, basic operational techniques including machine placement, barrier wall (loading, placement and handling), ditching, truck loading, patch removal, and grading. Due to state licensing requirements, members should have a CDL *Prerequisites for this course are:* basic knowledge of excavation and road work. **Note: 5 member max per class.**

Date	Start Time	Location
Mar. 2-6, 2026	7:00 A.M.	1143
Mar. 9-13, 2026	7:00 A.M.	1143
Mar. 16-20, 2026	7:00 A.M.	1143
Mar. 23-27, 2026	7:00 A.M.	1143

Introduction to Hydro-Vac Excavation

This 40-hour course is designed to provide a program for operators to develop the skills needed to operate a hydro “vacuum” excavation machine. Each student will demonstrate utility locating “potholing” and trenching techniques. Material covered will include, how a hydro excavator system works, safety concerns, DOT regulations and inspections, OSHA excavation regulations and systems trouble shooting. Due to state licensing requirements, members should have a CDL with “Tanker” endorsement prior to attending this class.

Date	Start Time	Location
Feb. 9-13, 2026	7:00 A.M.	1149
Feb. 16-20, 2026	7:00 A.M.	1149
Feb. 23-27, 2026	7:00 A.M.	1149
Mar. 2-6, 2026	7:00 A.M.	1149

Dirt Equipment Certification

Advanced Excavator Techniques

This class is designed for the experienced excavator operator. Members who register for this class must be proficient and have a minimum of 4,000 hours of job site experience on a track backhoe within the last 10 years. Classroom topics include OSHA related safety topics, terms and definitions, operating procedures and techniques, rigging and load charts, soil mechanics, understanding grades, pipe lasers and laser set-up, excavating in the presence of or around underground utilities, all types of related excavation work, demolition, UST removal, sloping and the use of trench boxes (ditch shields). Members must pass a written test before they take the practical test. Both the written and practical tests must be passed to become excavator certified.

Date	Start Time	Location
Nov. 24-26 2025	7:00 A.M.	1133
Dec. 15-17, 2025	7:00 A.M.	1133
Apr. 6-8, 2026	7:00 A.M.	1133

Advanced Dozer Techniques

This 4-hour class is for the experienced finish dozer operator. Members who register for this class must be proficient and have at least 4,000 hours of job site experience on a dozer within the last 10 years. Classroom topics such as terms and definitions, safety, job planning, grading methods and techniques, grade stakes and print reading, laser setup and use are all covered in the classroom. Members must pass the written test before they take the practical test. Both the written and practical tests must be passed to become dozer-certified.

Date	Start Time	Location
Dec. 18, 2025	7:00 A.M.	1142
Apr. 9, 2026	7:00 A.M.	1142

Advanced Blade Techniques

This 4-hour class is for the experienced blade operator. Members who register for this class must already be proficient and have 4,000 hours of job site experience on a blade within the last 10 years. Topics covered include terms and definitions, safety, job planning, grading methods and techniques, grade stakes and print reading, laser setup and use are all covered in the classroom. Members must pass the written test before they take the practical test. Both the written and practical tests must be passed to become blade certified.

Date	Start Time	Location
Dec. 18, 2025	11:30 A.M.	1142
Apr. 9, 2026	11:30 A.M.	1142

Road Construction



Introduction to Asphalt Paving and Rolling

In this 40-hour course, members will learn the basic components and setup procedures associated with asphalt pavers. Safety, setup, and proper use of the machines will be the main focus of this class. Members will also learn about the different asphalt rollers and rolling patterns. This course will include a blend of classroom and hands-on training.

Note: 10 member max per class.

Date	Start Time	Location
Dec. 8-12, 2025	7:00 A.M.	2123
Jan. 5-9, 2026	7:00 A.M.	2123
Feb. 2-6, 2026	7:00 A.M.	2123
Feb. 23-27, 2026	7:00 A.M.	2123
Mar. 30-Apr. 3, 2026	7:00 A.M.	2123

Fundamentals of Asphalt Paving and Rolling

This 40-hour class is a continuation of where the Introduction to Asphalt Paving and Rolling class left off. Members will learn how to pave and roll around different obstacles such as light poles, manholes and different types of curbs. Students will be focusing on creating and rolling different types of joints used on mainline jobs as well as small jobs such as driveways and parking lots. Members will also learn how to

pave and roll intersections and cul-de-sac's. The course will include some classroom work, but will mainly be hands-on training. *Prerequisite:* Introduction to Paving and Rolling class. **Note: 10 member max per class.**

Date	Start Time	Location
Jan. 12-16, 2026	7:00 A.M.	2123
Feb. 9-13, 2026	7:00 A.M.	2123
Mar. 2-6 2026	7:00 A.M.	2123
Apr. 6-10, 2026	7:00 A.M.	2123

Introduction to Road Grinding

This class is an introduction to the controlled cold milling of pavement to restore the surface to a specified profile. Bumps, ruts, and other surface irregularities are removed, leaving a uniform textured surface. This is an introductory course designed for the individual with little to no experience in this field. This course will include classroom as well as hands-on training.

Date	Start Time	Location
Dec. 15-19, 2025	7:00 A.M.	2122
Jan. 5-9, 2026	7:00 A.M.	2122
Jan. 19-23, 2026	7:00 A.M.	2122
Feb. 23-27 2026	7:00 A.M.	2122

Intro to Material Transfer Vehicles & Road Wideners

In this 24-hour class, members will be introduced to material transfer vehicles (shuttle buggies) and road wideners. Through a combination of lecture and hands-on training, members will learn about safety, set up, operation and how these machines are used on a variety of road jobs today.

Date	Start Time	Location
Feb. 16-18, 2026	7:00 A.M.	2123
Mar.9-11, 2026	7:00 A.M.	2123

Concrete Pumping and Belt Placement

This 40-hour course will be offered to members who would like to work with and learn about modern concrete pumping systems. Members will learn to work with various applications, components, outputs, pump capacities and line pressures that are associated with truck mounted pumps. Safe and efficient machine setup, assembly of the piping, start-up, operating the pump, slump mixture, blockages, preventive maintenance and cleanout will all be covered during the week. Due to state licensing requirements, members should have a CDL.

Date	Start Time	Location
Jan. 12-16, 2026	7:00 A.M.	1149
Feb. 2-6, 2026	7:00 A.M.	1149
Mar. 16-20, 2026	7:00 A.M.	1149
Apr. 6-10, 2026	7:00 A.M.	1149

Introduction to Concrete Plants *

This 40-hour class is designed to enable members to identify types of concrete plants, describe plant components, personnel and safety concerns. Members will be able to explain different characteristics of concrete, list all integral parts of a concrete plant and their function in order to familiarize themselves and reduce risk. This is an entry level class for members with little to no concrete plant experience. This introduction class will be a blend of classroom lectures and a plant tour.
Note: 5 member max per class.

Date

** Course will be offered on an as-needed basis. Please contact ASIP to express interest.*

Assistant Plant Operator *

This is a 40-hour class is designed to increase the skill level of existing assistant plant operators and enable new participants to fill the assistant plant operator position on concrete plants. Members will learn maintenance and lube procedures, inspection and frequency, start up and shut down procedures, resolve common repair items. Members will also learn how to order product needed and identify when running low. This class will cover cold weather protection and how to operate cement storage box.
Note: 5 member max per class.

Date

** Course will be offered on an as-needed basis. Please contact ASIP to express interest.*



Site Work, Staking, GPS, Drones



Grade Stakes, Layout and Plan Reading

This class is designed to help members develop and utilize the skills involved in job site construction. Members will be trained to read and set grade stakes, learn how to read and interpret blueprints as well as lay out a job site based on criteria given. As part of this class, members may use a laser, transit, hand level, and various other instruments to develop basic site work skills. Some of the exercises to be performed will be basic computations and arithmetic, job site layout and instrument set up.

Date	Start Time	Location
Feb. 9-13, 2026	7:00 A.M.	1142
Feb. 23-27, 2026	7:00 A.M.	1142
Mar. 23-27, 2026	7:00 A.M.	1142

Introduction to Digital Take-Off

This course explores the knowledge needed to utilize take-off hardware and software to calculate volumetric calculations. Students will utilize skills relating to grade stakes, plan reading, layout, global positioning systems, metric and mathematical computations.

Date	Start Time	Location
Feb. 23, 2026	7:00 A.M.	2115

GPS: Survey and Rover Pole

This 40-hour class will introduce members to Topcon, Trimble and Leica GPS survey equipment. Members will be trained how to set up a rover pole, controller, and base station as well as learn how to use the software associated with each controller. Through a combination of lecture and hands-on exercises, while using the equipment provided, members will calibrate a job site, establish control points, shoot topographical elevations, transfer GPS information to grade stakes as well as use other functions in the controller to layout a jobsite and compute distances and quantities.

Date	Start Time	Location
Jan. 5-9, 2026	7:00 A.M.	1142
Feb. 16-20, 2026	7:00 A.M.	1142
Mar.30-Apr. 3, 2026	7:00 A.M.	1142

GPS and Machine Control

In this 40-hour class intended for seasoned dozer operators, members will be trained to use Topcon, Trimble and Leica GPS machine control hardware and software. Through lecture and hands-on exercises, members will learn how to navigate the machine interface, perform grading tasks, transfer files between equipment as well as basic troubleshooting and maintenance. In the event of inclement weather, class will be held indoors where the use of robotic total stations and simulators will be used to supplement the hands-on portion of the class. *Prerequisite:* Members need a minimum of 1,000 hours operating a dozer or excavator in the last 5 years or the Dozer or Excavator Proficiency.

Date	Start Time	Location
Nov. 17-21, 2025	7:00 A.M.	1142
Feb. 23-27, 2026	7:00 A.M.	1142
Mar. 2-6, 2026	7:00 A.M.	1142
Mar. 9-13, 2026	7:00 A.M.	1142
Mar. 16-20, 2026	7:00 A.M.	1142



Drone Level 1

This course provides operators with the knowledge required to obtain an FAA unmanned aerial system remote pilot certificate and develop the skills needed to safely operate a UAV commercially. Each member will demonstrate an understanding of FAA Part 107 regulations and testing procedures. The material covered in this course includes regulations, specific techniques used on construction and inspection sites and basic flight procedures. Upon completion of this course, student will be able to: identify different types of drone missions used for construction, understand the options for processing data, demonstrate basic drone flying competency and take and pass the FAA Part 107 exam.

Date	Start Time	Location
Feb. 9-13, 2026	7:00 A.M.	1143
Feb. 16-20, 2026	7:00 A.M.	1143



Drone Level 2

This course provides operators with the skills to use drones for construction applications. Materials covered in this course will include specific techniques used on construction sites, advanced flight procedures used in inspections, automated data collection for surveying applications, photometric data processing and choosing payloads for specific mission parameters. *Prerequisite:* Member must have taken the Drone Level 1 course and be in the process of testing with the FAA.

Date	Start Time	Location
Mar. 16-20, 2026	7:00 A.M.	1143
Mar. 23-27, 2026	7:00 A.M.	1143



OECP Certification Test Dates

Written Examinations

Date	Start Time	Location
Sept. 27, 2025	8:00 A.M.	1140
Nov. 15, 2025	8:00 A.M.	1140
Dec. 13, 2025	8:00 A.M.	1140
Jan. 31, 2026	8:00 A.M.	1140
Feb. 21, 2026	8:00 A.M.	1140
Mar. 21, 2026	8:00 A.M.	1140
Apr. 18, 2026	8:00 A.M.	1140
May 9, 2026	8:00 A.M.	1140
Jun. 13, 2026	8:00 A.M.	1140
Jul. 11, 2026	8:00 A.M.	1140

Practical Examinations

Date	Start Time	Location
Oct. 11, 2025	7:00 A.M.	1140
Nov. 1, 2025	7:00 A.M.	1140
Dec. 6, 2025	7:00 A.M.	1140
Mar. 7, 2026	7:00 A.M.	1140
Apr. 11, 2026	7:00 A.M.	1140
May 2, 2026	7:00 A.M.	1140
Jun. 20, 2026	7:00 A.M.	1140
Jul. 18, 2026	7:00 A. M.	1140

Overhead Practical Exams

Date	Start Time	Location
Nov. 1, 2025	7:00 A.M.	1140
Dec. 6, 2025	7:00 A.M.	1140
Mar. 7, 2026	7:00 A.M.	1140
Apr. 11, 2026	7:00 A.M.	1140
May 2, 2026	7:00 A.M.	1140
Jun. 20, 2026	7:00 A.M.	1140
Jul. 18, 2026	7:00 A.M.	1140

** More testing dates may be added throughout the training season. Please call the training site Certification Department at (815) 722-3201 for more information on OECP testing.*

Crane Department



Introduction to Cranes

This 40 hour class has been designed as an entry level crane class for the member looking to possibly become a crane operator. Topics to be covered in this class included types of cranes, components, preventative maintenance, basic rigging and signaling. The Qualified Signal Person Safety Training is included in this class. **Note: 9 member max per class.**

Date	Start Time	Location
Nov. 10-14, 2025	7:00 A.M.	2023
Dec. 1-5, 2025	7:00 A.M.	2023
Dec. 8-12, 2025	7:00 A.M.	2023
Dec. 15-19, 2025	7:00 A.M.	2023
Jan. 12-16, 2026	7:00 A.M.	2023
Feb. 2-6, 2026	7:00 A.M.	2023
Feb. 9-13, 2026	7:00 A.M.	2023
Mar. 9-13, 2026	7:00 A.M.	2023
Mar. 16-20, 2026	7:00 A.M.	2023
Mar. 23-27, 2026	7:00 A.M.	2023

Introduction to Tower Cranes *

This class is an introduction to tower cranes. This class will be run on an as needed basis based on interest from the members. prerequisites for the class are an OECP license and 2000 hours of documented crane experience in the last 5 years.

Date
* Course will be offered on an as-needed basis. Please contact ASIP to express interest.

Fundamentals of Hoisting and Rigging

This 80-hour class is designed for the beginner crane operator. Topics will include various aspects of craning, such as wire rope and rigging, proper setup procedures, load moment indicator (LMI) programming, load chart reading including calculations and deductions, operator responsibilities, assembly/disassembly and safe work practices. The class time is divided equally between classroom and hands-on training for hydraulic and friction cranes. *Prerequisite:* Introduction to Cranes or previously taken Fundamentals of Hoisting and Rigging. **Note: 9 member max per class.**

Date	Start Time	Location
Jan. 19-30, 2026	7:00 A.M.	2023
Feb. 23-Mar. 6, 2026	7:00 A.M.	2023
Mar. 30-Apr. 10, 2026	7:00 A.M.	2023

Advanced Hoisting and Rigging

This 40-hour class is designed around the crane operator looking to expand his or her knowledge and job type experience. The class consists of job-based experiences with operators working as a team. Each task must be completed on time and will be evaluated upon completion. All members attending this class will receive a Certificate of Completion. *Prerequisites:* Crane certified (OECP, Local 150 or City of Chicago) or prior completion of Fundamentals Hoisting and Rigging (80 Hour class). **Note: 6 member max per class.**

Date	Start Time	Location
Dec. 8-12 2025	7:00 A.M.	2025
Jan. 12-16, 2026	7:00 A.M.	2025
Mar. 9-13, 2026	7:00 A.M.	2025
Apr. 13-17, 2026	7:00 A.M.	2025

Principles of Friction Cranes

This 40-hour class is devoted to Crawler type Friction Cranes. Topics covered will be safety, maintenance, and operation. The different applications of Friction Cranes will also be covered. Fundamentals of Hoisting and Rigging is a prerequisite for this class. **Note: 6 member max per class.**

Date	Start Time	Location
Mar. 30-Apr. 3, 2026	7:00 A.M.	2025



Signal Person Safety Training

This class was developed to meet the new OSHA standard CC 1926.1428 Signal Person Qualification. This new standard is going to require any person signaling a crane to be a Qualified Signal Person and they will need documentation of taking both a written and practical examination. After successfully completing this class, a member would meet the requirements of a qualified signal person. The curriculum is all classroom based and will cover topics such as: hand signals, voice signals, power line safety, crane dynamics and more. Both a written and practical exam will be administered after the completion of the course.

Date	Start Time	Location
Nov. 13, 2025	7:00 A.M.	2023
Dec. 4, 2025	7:00 A.M.	2023
Dec. 11, 2025	7:00 A.M.	2023
Dec. 18, 2025	7:00 A.M.	2023
Jan. 15, 2026	7:00 A.M.	2023
Feb.5, 2026	7:00 A.M.	2023
Feb. 12, 2026	7:00 A.M.	2023
Mar. 12, 2026	7:00 A.M.	2023
Mar. 19, 2026	7:00 A.M.	2023
Mar. 26 2026	7:00 A.M.	2023

Rigging Person Safety Training

This 24-hour safety training class will provide you with a safety training certificate to help the contractor qualify you as a rigger. Topics covered will be selection and inspection of rigging equipment, types of hitches, rigging hardware, specialty attachments, and all applicable OSHA standards. In order to successfully pass this course, you must attend all three days of class, pass a written assessment, pass a practical inspection, and complete hands-on practical rigging exercises in the crane field. *Prerequisite:* Signal Person Safety Training.

Date	Start Time	Location
Nov. 24-26, 2025	7:00 A.M.	2025
Dec. 15-17, 2025	7:00 A.M.	2025
Feb. 9-11, 2026	7:00 A.M.	2025
Feb. 16-18, 2026	7:00 A.M.	2025
Mar. 2-4, 2026	7:00 A.M.	2025
Mar. 23-25, 2026	7:00 A.M.	2025

Mobile Crane

This 40-hour class is designed for members with 1,000 hours or more of crane related experience who would like to pursue Crane Certification. The curriculum is primarily classroom-based, offering little hands-on training. Course instructors will cover subjects pertaining to crane types, nomenclature/components, crane setup, and various crane accidents. The OSHA and ANSI standards will be covered with emphasis on power line safety, suspended personal platforms, and crane inspections, including shift, monthly, and annual. Other key topics include wire rope and rigging, hand signals, and principles of operation.

Date	Start Time	Location
Dec. 1-5, 2025	7:00 A.M.	2024
Jan. 26-30, 2026	7:00 A.M.	2024
Feb. 16-20, 2026	7:00 A.M.	2024
Mar. 16-20, 2026	7:00 A.M.	2024
Apr. 13-17, 2026	7:00 A.M.	2024

Crane Math and Load Charts

This 16-hour course was created for experienced and aspiring crane operators. The topics that will be covered include: working with percentages, fractions, decimals, conversions, and estimating weights through the use of standardized formulas. These skills will be taught with and without the use of calculators as the use of calculators is prohibited during certification exams. We will cover notes interpretation along with understanding and the utilization of load charts and range diagrams. We will utilize charts from various manufacturers and different crane types in this class. This class is recommended for those members preparing for crane certification.

Date	Start Time	Location
Nov. 10-11, 2025	7:00 A.M.	2024
Jan. 5-6, 2026	7:00 A.M.	2024
Jan. 19-20, 2026	7:00 A.M.	2024
Feb. 2-3, 2026	7:00 A.M.	2024
Apr. 6-7, 2026	7:00 A.M.	2024

Liebherr 1095 Assembly/Disassembly

This class is designed to introduce our members to the 1095 Liebherr truck crane. Throughout various hands-on exercises our members will set up, break down and operate the crane. This class is intended for members looking to familiarize themselves with Liebherr cranes and the new technology that is used during the assembly, disassembly and operation of the machine. **Note: 10 members max per class.**

Date	Start Time	Location
Feb. 23-27, 2026	7:00 A.M.	2025
Mar. 23-27, 2026	7:00 A.M.	2025



Heavy Equipment Technician Classes

4-Section Telescopic Boom D&A

This is a 24-hour course that covers the maintenance, inspection, disassembly and assembly of 4-section telescopic booms. This class is 90% hands on using a Trak International Maintenance Trainer.

Date	Start Time	Location
Jan. 6-8 2026	7:00 A.M.	1054
Mar. 17-19, 2026	7:00 A.M.	1054

Engine Disassembly and Assembly

This is a (32 hour) course that covers disassemble and assembly of diesel engines. This class is entirely hands-on. This class will be taught in 4 days.

Date	Start Time	Location
Dec. 16-19, 2025	7:00 A.M.	1049
Mar. 9-12, 2026	7:00 A.M.	1049

Power Train Systems

This is a 4-day (32- hour) course that covers operation and rules of a Planetary Gear Sets, Torque Converter theory of operation, and Powershift transmission theory of operation. This class is a split between hands on and classroom. Technicians will have the opportunity to take the hands-on training where it will benefit them the most. They will have a selection of several training aids. From transmission, final drive, and axle D & A to differential set up. We will also have equipment to perform pressure checks and run diagnostics on power train systems.

Date	Start Time	Location
Apr. 7-10, 2026	7:00 A.M.	1049

Journey Worker Hydrostatic Systems

This is a 32-hour course covering modern hydrostat drive systems, maintenance, troubleshooting and repair. This 4-day course will include, and explanation of electronic control systems used on hydrostatic drive m machines.

The operation and testing of hydrostatic components and control systems will be part of the course. Technicians will participate in testing and troubleshooting both the electronic control systems, hydraulic control systems as well as manual control systems. Maintenance and pump assembly and disassembly are also a part of this course.

Date	Start Time	Location
Oct. 21-24, 2025	7:00 A.M.	1049

Tier 4 Diesel Engine Emissions Systems

This course is 4-days (32-hours) & will give the student a strong foundation in Diesel Engine emissions systems, why they are they are used, and what pollutants they target. Upon completion, participants will be able to:

Date	Start Time	Location
Jan. 13-16, 2026	7:00 A.M.	1054
Mar. 31- Apr. 3, 2026	7:00 A.M.	1054

- Describe the functions, construction, types, styles, and applications of diesel engine crankcase ventilation systems.
- Identify and describe the construction, types, styles, and application of VGT turbochargers.
- Describe the functions, construction, and applications of diesel engine exhaust gas recirculation strategies.
- Explain the principles of operation of diesel exhaust emission aftertreatment systems and methods for performing inspection and diagnostic procedures.
- Explain the principles of operation of diesel exhaust fluid, SCR aftertreatment systems.
- Access service menus and use OEM software to perform regenerations, testing, and diagnostics.
- Identify and describe circuit monitoring strategies for out-of-range fault detection and identify and describe principles of fault detection and diagnosis.

The learning environment will be a 50/50 split between classroom and the service shop. Technicians will use CAT ET, John Deere Service Advisor, and Diesel Laptop to perform aftertreatment testing/data readings.

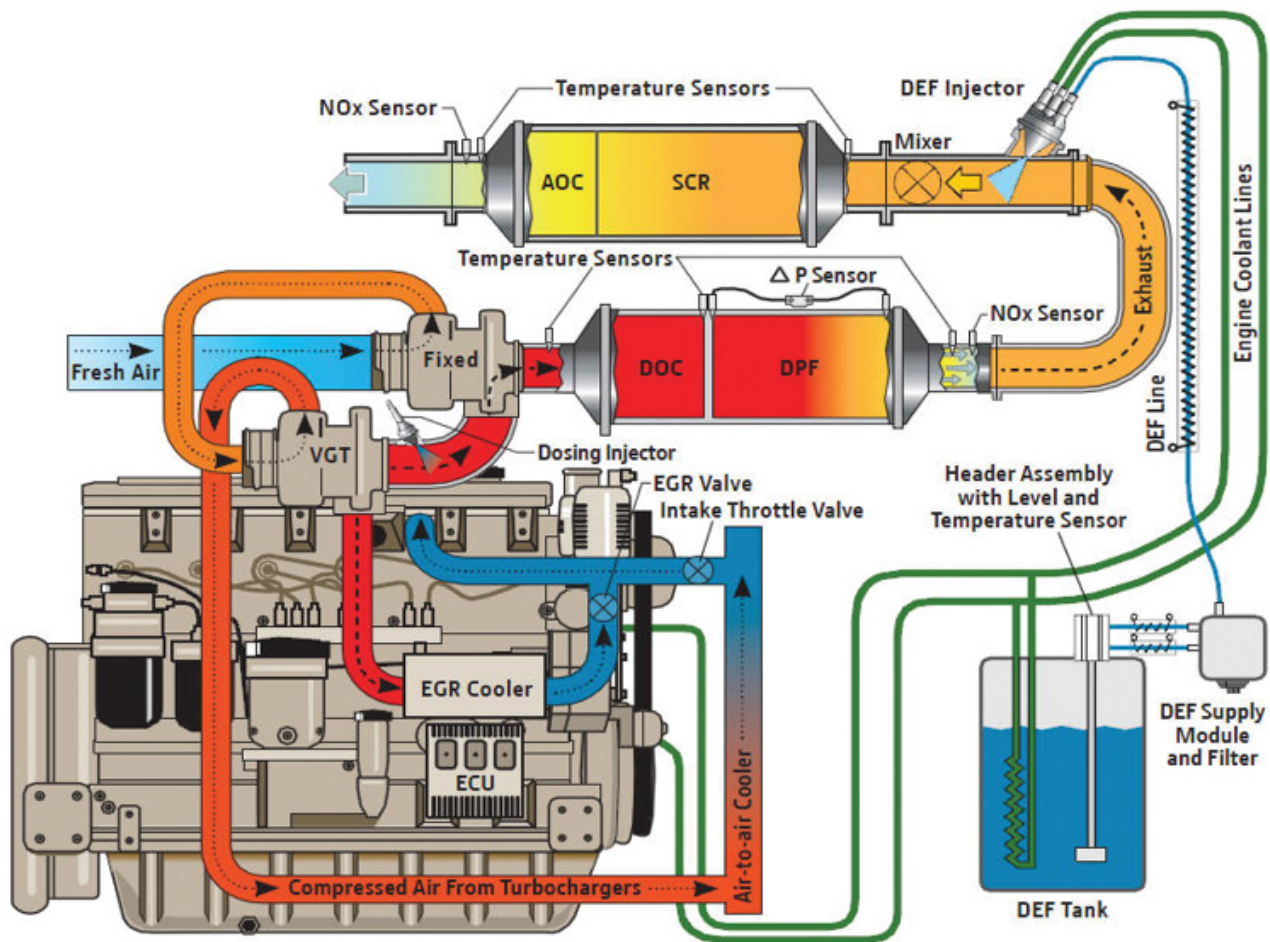

Journey Worker Hydraulics

This 32 hour course will give the student a strong foundation in hydraulic systems used in mobile equipment. Upon completion, participants will be able to:

Date	Start Time	Location
Feb. 24-27, 2026	7:00 A.M.	1034

- Describe the principles of hydraulics.
- Identify and describe the function of the components that make up a typical hydraulic system.
- Identify and read the schematic symbols in a typical hydraulic schematic.
- Understand the use and operation of load sensing variable displacement pumps.

The learning environment will be established in both the classroom and the service shop.



Journey Worker Electrical

This 32-hour course is designed for members who are new to electrical circuits as well as members who have some experience with electrical circuits. Topics that will be covered throughout this course are electrical theory, Ohm's law circuit calculations, electrical schematics, digital multimeter use and safety, electrical schematics, voltage drop testing methodology. This class will cover the function and testing of electrical components that are commonly used throughout the heavy equipment industry. There will be a balance of classroom and hands-on training provided to instill a methodical systematic approach to troubleshooting. Various instructor induced electrical faults on different types of equipment will be used to apply your electrical troubleshooting skills in a real-world environment. **Note: This is a 4-day course and is limited to 12 members per class.**

Date	Start Time	Location
Nov. 4-7, 2025	7:00 A.M.	1034
Feb. 17-20, 2026	7:00 A.M.	1034

Computer Based Diagnostics

This is a 4-day (32-hour) class that will give you a basic understanding of how to hook up and navigate computer software based diagnostic programs. Technicians will be taught CAT ET, John Deere Service Advisor, Diesel Laptop, Sauer Danfoss Plus 1, and Genie Web GPI. Class will be a 50/50 split between classroom and live diagnostics on machines in the training shop. Students will be given navigation books for all software covered.

Date	Start Time	Location
Feb. 10-13, 2026	7:00 A.M.	1054



Electronic Systems

This 32-hour course is designed for members who are new to troubleshooting electronically controlled systems. Topics that will be covered throughout this course are, electronically controlled fuel systems, multiplexing of machine control systems, sensor testing troubleshooting. There will be a balance of classroom and hands-on training provided to instill a methodical systematic approach to troubleshooting. Various instructor induced electrical faults on different types of equipment will be used to apply your electrical troubleshooting skills in a real-world environment. This class will be a 4-day course. This class will start Monday at 7:00 A.M. and will end Thursday afternoon at 3:30 P.M.

Date	Start Time	Location
Jan. 27-30, 2026	7:00 A.M.	1034
Mar. 3-6, 2026	7:00 A.M.	1034

*It is strongly recommended to take the computer-based diagnostics course prior to taking this course.

Introduction to Electric Drive Systems

This 32-hour class is designed for the technicians and maintenance professionals who deal with AC/DC electric drive motors and related control systems. Participants will gain practical knowledge and diagnostic skills through in-depth instruction for real world applications. Topics:

AC and DC electric drive motors: operation, construction, and differences. Motor wiring and phasing: proper techniques for phasing and connecting motor wiring for safe and efficient operation. Delta and wye motor connections: understanding and identifying delta and wye configurations and connecting motor leads correctly for both types. Transformers: principles of step-up and step-down transformers, voltage regulation, and installation considerations. Motor controllers: overview and application of AC and DC motor controllers including contactors, overloads, and variable frequency drives (VFD's). Speed sensor testing: methods for testing and troubleshooting motor speed sensors and encoders. AC generator diagnostics: diagnostic procedures for AC generators, including voltage output testing and troubleshooting.

Date	Start Time	Location
Oct. 14-17, 2025	7:00 A.M.	1034
Feb. 3-6, 2026	7:00 A.M.	1034
Apr. 14-17, 2026	7:00 A.M.	1034

Metal Fabrication and Basic Repair

Explore the basics of fabrication as it pertains to the repair of heavy equipment and tools. Learn and practice skills such as using a track torch with both Oxy/acetylene and plasma. Carbon arc gouging as it pertains to removing cracks or unwanted material. Oxy-Lance slice rod for cutting and track pin removal. Bolt extraction for removing broken bolts. Welding with pre and post heating techniques. Hard face welding when, why and how with both wire and stick. **Note: This is a 32-hour class limited to 6 members. The Vertical Welding Proficiency is a prerequisite for this class.**

Date	Start Time	Location
Dec. 8-11, 2025	7:00 A.M.	1053

Mechanical Diesel Fuel Systems

This 32-hour course is designed for members who are new to diesel fuel systems as well as members who have some experience working on diesel engines. Topics that will be covered throughout this course will be, functions operation and testing of low-pressure fuel system, inline injection pumps, rotary distribution pumps and high-pressure common rail pumps. There will be a balance of classroom and hands-on training provided to instill a methodical systematic approach to testing and troubleshooting. Multiple engines from different manufactures will be used to apply and advance your understanding of the various systems and improve your troubleshooting skills. **Note: This is a 4-day class and is limited to 12 members per class.**

Date	Start Time	Location
Oct. 28-31, 2025	7:00 A.M.	1034
Jan. 20-23, 2026	7:00 A.M.	1034
Mar. 16-19, 2026	7:00 A.M.	1034

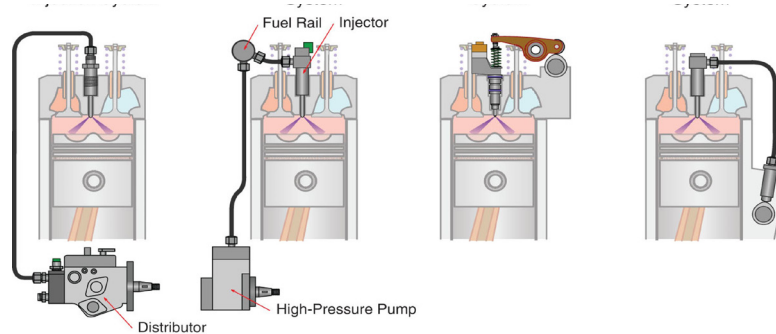

Intro to Mobile A/C - MACS 609 Cert. (AC1)

This is a 4 Day (32-Hour) course designed to train a person to properly service mobile air conditioning systems as well as provide each person taking the course the opportunity to become (MACS 609) certified to legally perform mobile air conditioning service work and purchase bulk refrigerant. At the present time, the certification is effective for a person's lifetime. Topics Covered Include:

Date	Start Time	Location
Mar. 10-13, 2026	7:00 A.M.	1053

- A. Refrigerant types and behavior
- B. Physical principles relating to air conditioning
- C. Refrigeration components
- D. Refrigerant control systems
- E. Refrigerant identification
- F. Performance testing an air conditioning system
- G. Leak detecting
- H. Recovering refrigerant
- I. Recycling refrigerant
- J. Evacuating a system
- K. Component replacement
- L. Adding lubricant
- M. Charging the system
- N. Environmental concerns relating to mobile air conditioning systems

Class will be a 50/50 split between classroom and hands on training.

Theory of Mobile A/C Testing & Adjusting (AC2)

This is a 4 Day (32-Hour) course designed to train a person to properly diagnose & test mobile air conditioning systems. Classroom will cover AC systems operation, performance, and temperature testing. Hands on training will cover the use of 3 different RRR machines and field set up recovery machines. The following topics will be covered.

Date	Start Time	Location
TBD	7:00 A.M.	1053

- A. Refrigerant types and behavior
- B. Physical principles relating to air conditioning
- C. Heating system design and repair
- D. Refrigeration components
- E. Refrigerant control systems
- F. Refrigerant identification
- G. Performance testing an air conditioning system
- H. Leak detecting
- I. Recovering refrigerant
- J. Recycling refrigerant
- K. Evacuating a system
- L. Flushing a system
- M. Component replacement
- N. Adding lubricant
- O. Charging the system
- P. Environmental concerns relating to mobile air conditioning systems

Considerable shop time will be devoted to hands-on practice of required service skills.

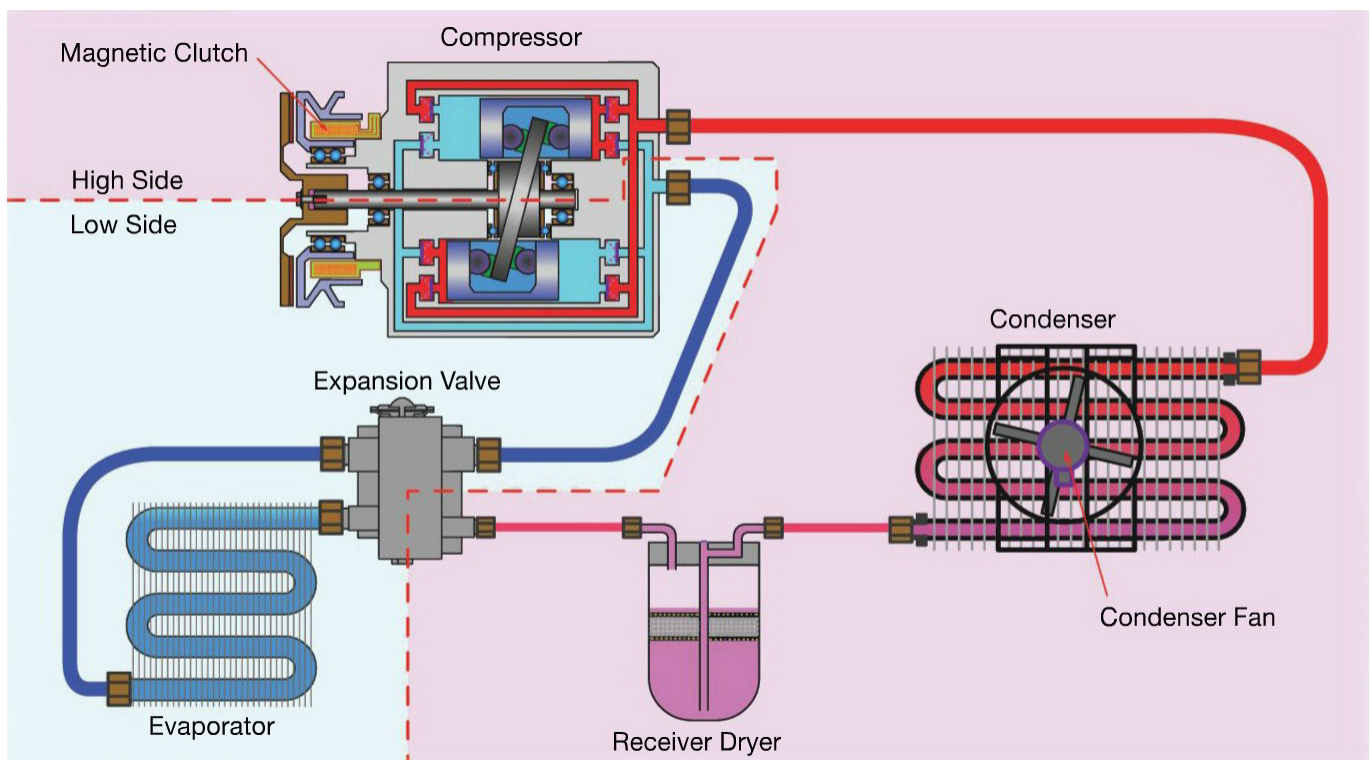

Heavy Equipment Welding Classes

FCAW and GMAW Welding

Students will be instructed in GMAW the processes of solid wire welding as well as FCAW including both self-shielded and gas-shielded flux core arc welding. Class will include instruction and discussion involving power supplies, filler metals, gasses, equipment, and equipment maintenance and setup. Class will discuss proper technique and setup procedures for multiple modes of metal transfer as well as when and how to use them. There will include a balance of classroom and hands on training including demonstration of flat, horizontal, vertical and overhead welding of mild steel. This class is 32-Hours and limited to 12 members per class.

Date	Start Time	Location
Jan. 19-22, 2026	7:00 A.M.	1053
Feb. 9-12, 2026	7:00 A.M.	1053

SMAW (Stick Welding) / NC3 Certification

This class will cover shielded metal arc welding (SMAW) a.k.a. stick welding. Students will have a day of classroom covering both Introduction to SMAW and Advanced SMAW. For those students wishing to obtain their NC3 welding certification written tests will be given for both sections where a passing score of 80% is needed. The balance of the class will be spent in the welding center where we will demonstrate the proper techniques of flat, horizontal, vertical and overhead welding on mild steel. Students will have time to practice their skills and for those trying to attain NC3 certification practical testing will be available.

Prerequisite: NC3 online E-learning courses for both Safety and the Principles of Welding and their online tests with a passing score of at least 80%.

This class is for anyone wishing to learn about SMAW with an opportunity for those who want to obtain an NC3 certification to do so. **Note: Class length is 32-hours and limited to 12 members per class.**

Date	Start Time	Location
Oct. 20-23, 2025	7:00 A.M.	1053
Mar. 16-19, 2026	7:00 A.M.	1053

Shielded Metal Arc Welding (SMAW)

This is a 4 day (32 hour) course covering Stick (SMAW) welding. There will be classroom discussion of equipment, safety, and proper technique. The welding shop portion will include demonstrations of proper technique as well as plenty of practice time. Welds can also be tested. Each section of the course will be limited to 12 members.

Date	Start Time	Location
Dec. 1-4, 2025	7:00 A.M.	1053
Jan. 26-29, 2026	7:00 A.M.	1053
Feb. 2-5, 2026	7:00 A.M.	1053
Feb. 16-19, 2026	7:00 A.M.	1053
Mar. 23-26, 2026	7:00 A.M.	1053

Drilling Classes



Exploratory Drilling Level 1

This 40-hour course is designed to provide a program for operators to develop the skills needed to operate a Geotechnical drill rig for soil and rock exploration. Each student will demonstrate basic auger, mud rotary and rock coring drilling techniques. Material covered will include drill rig operation, different drilling methods, drilling method applications, safety, drill rig inspections, routine maintenance and systems trouble shooting.

Date	Start Time	Location
Apr. 13-17, 2026	7:00 A.M.	1143
Apr. 20-24, 2026	7:00 A.M.	1143

This 40-hour course is designed to provide a program for operators with drilling experience to develop the skills needed to operate a Geotechnical drill rig using advanced techniques. Each member will demonstrate Denison soil coring, mud mixing, setting casing, angle drilling and rock coring drilling techniques. Material covered will included drill rig operation, drilling method applications, drilling safety instrumentation and grouting. *Prerequisites:* Exploratory Drill Level 1 or 1000 hours operating a geotechnical drill rig. **Note: 6 members max per class.**

Exploratory Drilling Level 2

This 40-hour course is designed to provide a program for operators with drilling experience to develop the skills needed to operate a Geotechnical drill rig using advanced techniques. Each member will demonstrate Denison soil coring, mud mixing, setting casing, angle drilling and rock coring drilling techniques. Material covered will included drill rig operation, drilling method applications, drilling safety instrumentation and grouting. *Prerequisites:* Exploratory Drill Level 1 or 1000 hours operating a geotechnical drill rig. **Note: 6 members max per class.**

Date	Start Time	Location
Jan. 26-30, 2026	7:00 A.M.	1143

Introduction to Geothermal Drilling

This course is designed to provide a program for operators to develop the skills needed to drill and install ground loops for geothermal heating and cooling in residential and commercial ground exchange systems. Each student will demonstrate soils recognition, mud mixing, air rotary drilling, mud rotary drilling, down the hole hammer drilling, setting loops, and geothermal grouting. Material covered will include drilling safety, basic loop design, air and mud drilling methods, setting casing, loop placement and grouting techniques. *Prerequisites:* IGSHPA Accredited Loop Installer; proficiency on a drill rig.

Date

** Course will be offered on an as-needed basis. Please contact ASIP to express interest.*

HDPE Pipe Fusion

This course is designed to provide a program for operators to develop the skills needed to build and install header systems (supply and return) for geothermal heat pumps. Each student will demonstrate basic trenching, pipe fusion, plan reading, pipe layout and fabrication techniques. Material covered will include: digging safety, basic header design, mechanical plan reading, pipe layout, and heat fusion welding techniques. Upon completion of the class, proficiency tests will be available in butt, socket, and saddle fusion of HDPE pipe.

Date

** Course will be offered on an as-needed basis. Please contact ASIP to express interest.*

Introduction to Geothermal Systems *

This course was designed to provide a program for operators to develop the skills needed to work on geothermal loop field installation. Each student will be introduced to ground loop installation drilling and grouting techniques. Material covered will include: types of heat exchanger systems, loop design, and thermal properties of geological formations. Upon successful completion of this class, students will receive accreditation from the International Ground Source Heat Pump Association (IGSHPA)

Date

** Course will be offered on an as-needed basis. Please contact ASIP to express interest.*

Drilling Mud and Solids Control Systems

The course is designed to assist in the development of skills related to the use of drilling fluids and grouts. Topics covered will be the importance of makeup water, drilling fluids for the water well geothermal and directional drilling industries, fluid testing, fluid troubleshooting, and geothermal and conventional grouting techniques and equipment. Students will be working with and handling the drilling fluid testing equipment, discussing past and current fluid technology, mixing and pumping thermally enhanced grout, and troubleshooting drilling fluid related issues.

Date	Start Time	Location
Feb. 9-13, 2026	7:00 A.M.	1143

Horizontal Directional Drill - Level 1

This 80-hour course is designed to familiarize the members with the operations of a modern Horizontal Directional Drill and Locating System. Training will include identifying utilities, utility safety awareness, personal protective equipment, machine maintenance, machine set-up and tear down, transportation and basic machine control. Trainees will also be introduced to the locating system and ancillary components. Members will work as part of a crew to plan and execute various directional bore shots. This course will consist of 40% classroom and 60% field training. Most of these jobs require a CDL.

Note: Maximum of 10 members per class. Must be able to lift 50 pounds. Some physical labor involved.

Date	Start Time	Location
Dec. 8-19, 2025	7:00 A.M.	1150
Jan. 19-30, 2026	7:00 A.M.	1150
Mar. 23-Apr. 3, 2026	7:00 A.M.	1150

Horizontal Directional Drill - Level 2

This 80-hour course will expand the skillset acquired in the Level 1 class. Members will simulate real world scenarios. Instruction will include drill fluid mixing and management, borehole volume and fluid flow calculations, appropriate tooling selection and product installation. Members will function as a drill crew would in the field. Members MUST complete Level 1 class to be eligible for this class. This course consists of 30% classroom and 70% field training. Most of these jobs require a CDL.

Note: Maximum of 10 members per class. Must be able to lift 50 pounds. Some physical labor involved.

Date	Start Time	Location
Feb. 2-13, 2026	7:00 A.M.	1150
Apr. 6-17, 2026	7:00 A.M.	1150

Caisson Drill Rig Class

This 40 hour course will consist of classroom instruction and hands-on training. Classroom topics will include safety, the effects of various soil types on drill operations and all types of drilling procedures. The hands-on portion of the class will be done using a hydraulic caisson drill rig. **Note: Class size will be limited to 8 members.**

Date	Start Time	Location
Jan. 5-9, 2026	7:00 A.M.	1143
Jan. 12-16, 2026	7:00 A.M.	1143
Jan. 19-23, 2026	7:00 A.M.	1143

Construction Material Inspectors

Basic Knowledge Courses

ICC General Requirements Special Inspector

Type	Date	Start Time	Location
Code	Dec. 18, 2025	7:00 A.M.	2034
Code	Jan. 15, 2026	7:00 A.M.	2034
Code	Jan. 26, 2026	7:00 A.M.	2034

Introduction to Resume Building *

This course provides members with the skills needed to create a professional resume. A review of proper layout, vocabulary / grammar, and maximizing potential will be discussed. Members will have a chance to create their own resume to be used in real life.

Date

** Course will be offered on an as needed basis. Please contact ASIP to express interest.*

Introduction to Interviewing Techniques *

The course provides members with the tools and confidence for a professional interview with our signatory companies. A review of proper interview etiquette and vocabulary / grammar to use during an interview. Members will have an opportunity to perform mock interviews with instructors.

Date

** Course will be offered on an as needed basis. Please contact ASIP to express interest.*

Math 1 - Basic Math

This course will provide members with basic math skills that are used daily in the CBI program. This course will review: conversions, rounding and reporting, order of operations and word problems. Members will be given a practice exam at the end of the class to simulate taking timed exams.

Date	Start Time	Location
Jan. 9, 2026	7:00 A.M.	2034
Mar. 20, 2026	7:00 A.M.	2034

Math 2 - Fractions

This course will provide members with math skills regarding fractions that are used daily in the CBI program. This course will review: proper fractions, addition / subtraction of fractions, and averaging of fractions. Members will be given a practice exam at the end of class to simulate taking timed exams.

Date	Start Time	Location
Jan. 9, 2026	11:30 A.M.	2034
Mar. 20, 2026	11:30 A.M.	2034

Concrete Inspection Courses

Floor Flatness *†

Dates

* Course will be offered on an as-needed basis. Please contact ASIP to express interest.

† This course is scheduled and offered by a 3rd party. Please contact ASIP for further information.

Post Tension Institute Unbonded PT Installer and Inspector - Level 1 & 2 *†

Dates

* Course will be offered on an as-needed basis. Please contact ASIP to express interest.

† This course is scheduled and offered by a 3rd party. Please contact ASIP for further information.

Pre-Cast/Prestressed Concrete Institute Plant Quality Control Techniques *†

Dates

* Course will be offered on an as-needed basis. Please contact ASIP to express interest.

† This course is scheduled and offered by a 3rd party. Please contact ASIP for further information.

Pre-Cast/Prestressed Concrete Institute Certified Field Auditor *†

Dates

* Course will be offered on an as-needed basis. Please contact ASIP to express interest.

† This course is scheduled and offered by a 3rd party. Please contact ASIP for further information.

Prestressed/Post Tension Concrete Inspection *

This course will provide members with skills needed to perform field inspections for prestressed / post tension concrete inspection. The course will review: prestressed / post tension concrete inspection, basic blueprints, tendon inspection, and stressing of the tendon. *Prerequisite:* Reinforced Concrete Inspection

Date

* Courses will be offered on an as needed basis. Please contact ASIP to express interest.

ICC Pre-Stressed Concrete Special Inspector *

Type	Date
Plan & Code*	* Courses will be offered on an as-needed basis. Please contact ASIP to express interest.

* Prerequisite for the Code class: Members must have taken the Prestressed/Post Tension Concrete Inspection and ICC Reinforced Concrete courses along with having a current ACI Concrete Field Testing Tech Grade 1 certification.

Reinforced Concrete Inspection

This course will provide members with skills needed to perform field inspections for reinforced concrete through a combination of classroom and hands on experience. The course will review: identifying reinforcing steel, basic blueprint reading, practice performing inspections on reinforcing steel. *Prerequisite:* ACI Concrete Field Testing Tech Grade 1

Date	Start Time	Location
Dec. 8, 2026	7:00 A.M.	2035
Jan. 12, 2026	7:00 A.M.	2035
Mar. 16, 2026	7:00 A.M.	2035

ICC Reinforced Concrete Special Inspector

Plan

Date	Start Time	Location
Dec. 9, 2025	7:00 A.M.	2035
Jan. 13, 2026	7:00 A.M.	2035
Mar. 17, 2026	7:00 A.M.	2035

Code

Date	Start Time	Location
Dec. 10-12, 2025	7:00 A.M.	2035
Jan. 14-16, 2026	7:00 A.M.	2035
Mar. 18-20, 2026	7:00 A.M.	2035

**Prerequisite for the Code class: Members must have taken the Reinforced Concrete Inspection course and have a current ACI Concrete Field Testing Tech Grade 1 certification.*



Masonry Inspection Courses

Masonry Inspection

This course will provide members with skills needed to perform field inspections for masonry grout and mortar through a combination of classroom and hands on experience. The course will review: masonry construction, basic blueprint reading, grout sampling and inspection, and mortar sampling and inspection.

Date	Start Time	Location
Dec. 1, 2025	7:00 A.M.	2035
Jan. 5, 2026	7:00 A.M.	2035
Mar. 9, 2026	7:00 A.M.	2035

ICC Structural Masonry Special Inspector

Plan

Date	Start Time	Location
Dec. 2, 2025	7:00 A.M.	2035
Jan. 6, 2026	7:00 A.M.	2035
Mar. 10, 2026	7:00 A.M.	2035

Code

Date	Start Time	Location
Dec. 3-5, 2025	7:00 A.M.	2035
Jan. 7-9, 2026	7:00 A.M.	2035
Mar. 11-13, 2026	7:00 A.M.	2035

**Prerequisite for the Code class: Members must have taken Masonry Inspection course. Reinforced Concrete Inspection course is recommended.*



Soils Inspection Courses

Soils - Classification

This course will provide members with skills needed to perform field inspections for soil classifications through a combination of classroom and hands on experience. The course will review: different soil classifications, visual manual procedure, unified soil classification procedure, both lab and field tests to determine soil properties.

Date	Start Time	Location
Jan. 5-6, 2026	7:00 A.M.	2034
Mar. 16-17, 2026	7:00 A.M.	2034

Soils - Field Inspection

This course will provide members with skills needed to perform field inspections for soil classifications through a combination of classroom and hands on experience. The course will review: different soil classifications, visual manual procedure, unified soil classification procedure, both lab and field tests to determine soil properties. *Prerequisite:* Soils-Classification

Date	Start Time	Location
Jan. 7-8, 2026	7:00 A.M.	2034
Mar. 18-19, 2026	7:00 A.M.	2034



ICC Soils Special Inspector

Plan

Date	Start Time	Location
Jan. 19, 2026	7:00 A.M.	2034
Feb. 9, 2026	7:00 A.M.	2034
Mar. 2, 2026	7:00 A.M.	2034

Code

Date	Start Time	Location
Jan. 20-22, 2026	7:00 A.M.	2034
Feb. 10-12, 2026	7:00 A.M.	2034
Mar. 3-5, 2026	7:00 A.M.	2034

*Prerequisites for the Code class: Members must have taken the Soils-Classification and Soils-Field Inspection courses.

Structural Steel Inspection Courses

AWS - Certified Welding Inspector * †

Dates

* Course will be offered on an as-needed basis. Please contact ASIP to express interest.

† This course is scheduled and offered by a 3rd party. Please contact ASIP for further information.

High-Strength Bolting Inspection

This course will provide members with skills needed to perform field inspections on high strength bolts through a combination of classroom and hands on experience. This course will review: installation methods, inspection methods, material identification and verification as well as basic blueprint reading

Date	Start Time	Location
Dec. 15, 2026	7:00 A.M.	2035
Feb. 16, 2026	7:00 A.M.	2035
Mar. 23, 2026	7:00 A.M.	2035

ICC Structural Steel and Bolting Special Inspector

Plan

Date	Start Time	Location
Dec. 16, 2026	7:00 A.M.	2035
Feb. 24, 2026	7:00 A.M.	2035
Mar. 24, 2026	7:00 A.M.	2035

Code

Date	Start Time	Location
Dec. 17-19, 2026	7:00 A.M.	2035
Feb. 25-27, 2026	7:00 A.M.	2035
Mar. 25-27, 2026	7:00 A.M.	2035

*Prerequisite for the Code class: Members must have taken the High-Strength Steel Bolting Inspection course.

Spray-Applied Fireproofing Inspection

This course will provide members with skills needed to perform field inspections on spray-applied fireproofing through a combination of classroom and hands on experience. This course will review: identifying materials, basic blueprints / submittals, thickness inspection, bond strength testing, adhesion / cohesion testing, and density testing.

Date	Start Time	Location
Jan. 26, 2026	7:00 A.M.	2034
Feb. 16, 2026	7:00 A.M.	2034
Mar. 2, 2026	7:00 A.M.	2034

ICC Spray-Applied Fireproofing Special Inspector

Type	Date	Start Time	Location
Code & Plan	Jan. 27-29, 2026	7:00 A.M.	2034
Code & Plan	Feb. 17-19, 2026	7:00 A.M.	2034
Code & Plan	Mar. 3-5, 2026	7:00 A.M.	2034

*Prerequisite for the Code and Plan classes: Spray-Applied Fireproofing Inspection course.

Structural Blueprint Reading

This course will provide members with skill needed to navigate structural blueprints for several types of inspections in the field through a combination of classroom and hands on experience. This course will review: basic understanding of blueprint organization, symbols, notes, details, drawing views.

Date	Start Time	Location
Jan. 12-14, 2026	7:00 A.M.	2034
Mar. 23-25, 2026	7:00 A.M.	2034

Welding Symbols

This course will provide members with skills needed to identify and interpret welding symbols. This course will review: joint types, identification of weld symbols and reading welding symbols.

Date	Start Time	Location
Jan. 22, 2026	7:00 A.M.	2035
Feb. 5, 2026	7:00 A.M.	2035

Welding Blueprints

This course will provide members with skills needed to understand and read weld symbols found on blueprints through a combination of classroom and hands on experience. This course will review: Structural blueprints, Fabrication Shop blueprints and Erector blueprints. *Prerequisite:* Welding Symbols course

Date	Start Time	Location
Jan. 22, 2026	11:30 A.M.	2035
Feb. 5, 2026	11:30 A.M.	2035

Welding Inspection

This course will provide members with skills needed to perform field inspections on structural welds through a combination of classroom and hands on experience. The course will review: identification of weld types, different inspection methods, basic blueprint, and inspection on welds. *Prerequisite:* Welding Blueprints course

Date	Start Time	Location
Jan. 23, 2026	7:00 A.M.	2035
Feb. 6, 2026	7:00 A.M.	2035

ICC Structural Welding Special Inspector

Plan

Date	Start Time	Location
Jan. 30, 2026	7:00 A.M.	2034
Feb. 13, 2026	7:00 A.M.	2034

Code

Date	Start Time	Location
Feb. 2-4, 2026	7:00 A.M.	2035
Feb. 16-18, 2026	7:00 A.M.	2035

**Prerequisites for the Code class: Members must have taken SMAW 1, GMAW 1 and Welding Inspection courses.*

Introduction and IDOT Courses

ASIP introduction courses give a general overview of inspection responsibilities and go over in depth some of the more challenging sections of the IDOT courses (calculations, charting, table, etc.). These courses are required prior to taking the IDOT courses and the schedule is pending on the IDOT course calendar. Please visit the ASIP website (www.asiplocal150.org) for availability and registration. Please see the below listed links to view the IDOT training schedule and contact ASIP to get registered for classes.

Introduction to Aggregate Technician

This course will provide members with an introduction / overview of the material covered in the IDOT Aggregate Technician course and go over in depth some of the more challenging sections of the course (calculations, charting, tables, etc); provide members with skills needed to perform QC/QA inspector responsibilities in both the laboratory and field through a combination of classroom and hands on experience.

Date	Start Time	Location
TBD		

Introduction to Portland Cement Concrete - Level 1

This course will provide members with an introduction / overview of the material covered in the IDOT Portland Cement Concrete Level 1 course and go over in depth some of the more challenging sections of the course (calculations, charting, tables, etc.); provide members with skills needed to perform QC / QA inspector responsibilities in the field through a combination of classroom and hands on experience.

Date	Start Time	Location
TBD		

Introduction to Portland Cement Concrete - Level 2

This course will provide members with an introduction / overview of the material covered in the IDOT Portland Cement Concrete Level 2 course and go over in depth some of the more challenging sections of the course (calculations, charting, tables, etc.); provide members with skills needed to perform QC/QA inspector responsibilities in both the field and plant through a combination of classroom and hands on experience.

Date	Start Time	Location
TBD		

Introduction to Portland Cement Concrete - Level 3

This course will provide members with an introduction / overview of the material covered in the IDOT Portland Cement Concrete Level 3 course and go over in depth some of the more challenging sections of the course (calculations, charting, tables, etc.); provide members with skills needed to perform QC/QA inspector responsibilities in both the field and plant through a combination of classroom and hands on experience.

Date	Start Time	Location
TBD		

Introduction to Hot Mix Asphalt - Level 1

This course will provide members with an introduction / overview of the material covered in the IDOT Hot Mix Asphalt Level 1 course and go over in depth some of the more challenging sections of the course (calculations, charting, tables, etc.); provide members with skills needed to perform QC / QA inspector responsibilities in both the laboratory and field through a combination of classroom and hands on experience.

Date	Start Time	Location
TBD		

Introduction to Hot Mix Asphalt - Level 2

This course will provide members with an introduction / overview of the material covered in the IDOT Hot Mix Asphalt Level 2 course and go over in depth some of the more challenging sections of the course (calculations, charting, tables, etc.); provide members with skills needed to perform QC / QA inspector responsibilities in both the field and plant through a combination of classroom and hands on experience.

Date	Start Time	Location
TBD		

Introduction to Hot Mix Asphalt - Level 3

This course will provide members with an introduction / overview of the material covered in the IDOT Hot Mix Asphalt Level 3 course and go over in depth some of the more challenging sections of the course (calculations, charting, tables, etc.); provide members with skills needed to perform QC / QA inspector responsibilities in both the field and plant through a combination of classroom and hands on experience.

Date	Start Time	Location
TBD		

IDOT Documentation of Contract Quantities provided by Illinois Center for Transportation

<https://ict.illinois.edu/outreach/documentation-training/>

IDOT QC/QA Training Courses provided by Lake Land College

<https://www.lakelandcollege.edu/idot-quality-management-training-program/>

IDOT S33 Soils provided by IDOT

<https://idot.illinois.gov/doing-business/material-approvals/soils/index>

American Concrete Institute (ACI)

ACI Concrete Field Testing Technician Grade 1

This is a one day course is a review / exam prep immediately followed by the ACI administered certification exam / practical. These class dates are based on the availability of exam dates and may change due to ACI's scheduling.

Date	Start Time	Location
TBD		

ACI Concrete Field Testing Grade 1 will cover all Seven ASTM Standards covered / required by the American Concrete Institute (ACI) to take both the written and practical portions of the ACI Concrete Field Technician Grade 1 Certification. To become certified, you must pass the written exam and all seven practical exams administered by ACI personnel.

Please check the two websites below for availability of the ACI Proctored Exams and call the Training Center to register for the review session corresponding to the exam date.

ACI Indiana Chapter: www.indianaaci.org/certification

ACI Midwest Resource Center: www.concrete.org/events/eventscalendar

Please see ASIP Class Reimbursement Policy prior to scheduling individual classes at third party facilities.

Commercial Truck Driving



Entry Level Drivers Training (ELDT)

This class was designed to teach members how to complete a thorough pre-trip inspection of a commercial vehicle along with learning how to operate and maintain a commercial vehicle properly and safely. This class meets the FMCSA's ELDT Theory / Classroom Requirements.

Date	Start Time	Location
Dec. 1-5, 2025	7:00 A.M.	2034
Mar. 2-6, 2026	7:00 A.M.	2034
Mar. 16-20, 2026	7:00 A.M.	2034
Mar. 30-Apr. 3, 2026	7:00 A.M.	2034

Once members have completed this class, they will need to continue on with the skills and range driving portions of the training prior to testing. **This class will be limited to 10 members per class.**

MAP & DIRECTIONS

19800 West South Arsenal Road
Wilmington, IL 60481



Driving Directions:

From the North: Travel South on I-355. Exit onto I-55 South, and continue to Exit 241. Exit and travel East to Illinois Route 53. Turn left (North) and continue to W. Arsenal Road. Turn right (East). The Training Site will be on your left-hand side.

From the South: Travel North on I-55, and continue to Exit 241. Exit and travel East to Illinois Route 53. Turn left (North) and continue to W. Arsenal Road. Turn right (East). The Training Site will be on your left-hand side.

From the East: Travel West on Wilmington/Peotone Road to Old Chicago Road. Turn right (North) and continue to Quigley/Arsenal Road. Turn left (West). The Training Site will be on your right-hand side.

From the West: Travel East on I-80. Exit onto I-55 South, and continue to Exit 241. Exit and travel East to Illinois Route 53. Turn left (North) and continue to W. Arsenal Road. Turn right (East). The Training Site will be on your left-hand side.

WWW.ASIPLOCAL150.ORG

Welcome to ASIP Local 150

Local 150's training center is situated on 300-plus acres in Wilmington, IL. The center boasts 342,000 square feet of space housing an indoor training area, almost 200 pieces of heavy equipment, 30 classrooms, construction material testing lab, state of the art welding facility, equipment simulator lab, a 200-seat auditorium, and much more. Instructors are available to members six days a week, Monday through Saturday, except holidays.

Local 150 offers four apprenticeship programs: Heavy Equipment Operator, Heavy Equipment Repair Technician, Geothermal/Well Driller, and Construction Material Inspector (Field Inspector). We are currently only accepting applications for Heavy Equipment Repair Technicians. To obtain an application, please go to any one of our [District Halls](#) with your valid driver's license and a \$25 money order to fill out a request for an application packet. See our [FAQ](#) for more information.

We will begin accepting applications for Heavy Equipment Operator, Geothermal/Well Driller and Construction Material Inspector (Field Inspector) during the Fall of 2019.

UNION YES

OECP

James M. Sweeney
Chairman

David Snelten
Secretary

Brian Roland
Coordinator

19800 West South Arsenal Road
Wilmington, Illinois 60481

The apprenticeship website is available to all members and contains the following information:

- District Union Meeting dates and times
- Class listings with descriptions, prerequisites, dates, times and availability
- Equipment Availability and the option to view or cancel a reservation if needed
- OECP Information
- Additional News and Information
- Your own training records:
 - Transcripts
 - Site equipment usage
 - On the Job training summary
 - Dispatch history (*apprentices*)

Your personal contact information can also be changed here, though this will only affect your Training Site Records, as we do not share contact information with Dispatch.

To access these items, you must first create a login for yourself or call the training site to have one created. If the training site has your name, registration number, and date of birth on record, you may create your own login online. If we do not have this information or you have never used the training site, please call 815-722-3201 and we will gladly create a login for you.



Local 150 Legacy Brick Paver Order Form



Purchase a personalized brick paver to be installed in the Memorial Garden Walkway located at the:

William E. Dugan Training Center in Wilmington, IL

Paver Bricks are \$50 each and include:

3 Lines of Standard Text, 15 characters or Spaces per line, optional images to be placed as indicated on the layout area

Contact Name: _____

Address: _____

City: _____ State: _____ Zip: _____

Telephone: _____ Email: _____

Please make check payable in the amount of \$50.00 to: **Local 150 Apprenticeship Fund**. Drop off or mail order form to: **ASIP Local 150, 19800 W. South Arsenal Rd., Wilmington, IL 60481** Attn: Jill Eichelberger

Payment Information

Check # _____ Date Paid: _____

Name as it appears on account: _____

Money Order # _____ Date Paid: _____

Name of Issuing Bank or Institution: _____

Please print the message as you would like it to appear on the brick paver. Illustrate upper and lower case (case will appear as it does on this form). 15 characters maximum per line unless an image is selected (grey areas cannot include text if an image is selected). Text will be standard size, font, and style. Please print clearly.

Images consume 4 to 6 characters on two of the lines.

Image No. _____

Image No. _____

Line #1 _____

Line #2 _____

Line #3 _____

I have proofread my imprint / message and approve it for production. I understand that Local 150 is not responsible for errors contained in the copy as it is submitted. Local 150 reserves the right to deny application and or content for any reason.

Signature: _____ Date: _____

Images below are available to be placed on your brick paver. Please indicate the image number in the grey area of the brick paver above that you would like image placed. Please note that size and location of images are approximate and may vary slightly.



1



2



3



4



5



JOHN DEERE

6



7



8



Local 150 Apprenticeship and Skill Improvement Program Trustees

Union

James M. Sweeney- Chairman
I.U.O.E. Local 150
President-Business Manager

Michael R. Kresge
I.U.O.E. Local 150
Recording-Corresponding Secretary

Marshall E. Douglas
I.U.O.E. Local 150
Treasurer

David A. Fagan
I.U.O.E. Local 150
Financial Secretary

Jeffrey A. Horne
I.U.O.E. Local 150
Vice President

Steven M. Cisco
I.U.O.E. Local 150

Management

David Snelten- Sec.-Treasurer
Excavators, Inc.
Snelten, Inc.

G. Larry Eckardt
Chicagoland Crane Assoc.
Imperial Crane Services, Inc.

Steve Michaels
N.W. Indiana Contractors Assoc.
Superior Construction

Daniel R. Plote
Northern IL Material Producers Assoc.
Beverly Materials LLC

David Rock
Illinois Road Builders Assoc.
IHC Construction Co., LLC

William Collins
Underground Contractors Association
R.W. Collins